

2 - Loading table 1000

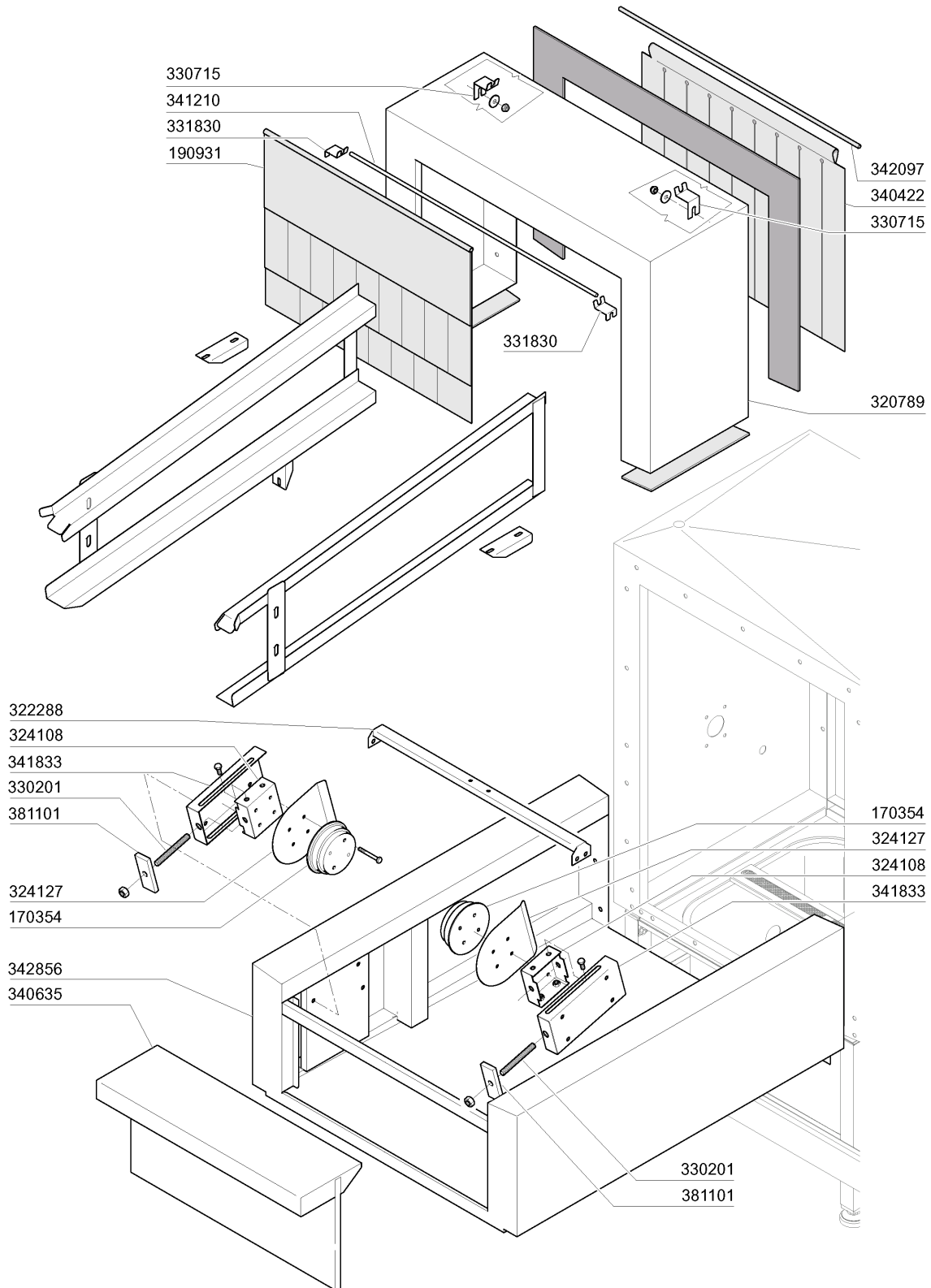

M.G. 10/07

2 - Loading table 1000

CODE	DESCRIPTION
170354	ROLLER
190931	CURTAIN OUT BTM-NE/2
320789	HOOD
322288	SUPPORT FOR GUIDES
324108	SUPPORT
324127	PANEL
330201	ROD FOR BELT ADJUSTING "N"
330715	UPPER BRACKET CURTAIN SNL-SE
331830	BRACKET FOR CURTAIN
340422	SHAFT FOR CURTAIN AC-ACR
340635	PANEL FOR TABLE 1000 NL
341210	CURTAIN SHAFTS N 2S GM
341833	SUPPORT
342097	SHAFT
342856	INLET TABLE
381101	PLATE

3 - Prewash Assembly 900mm

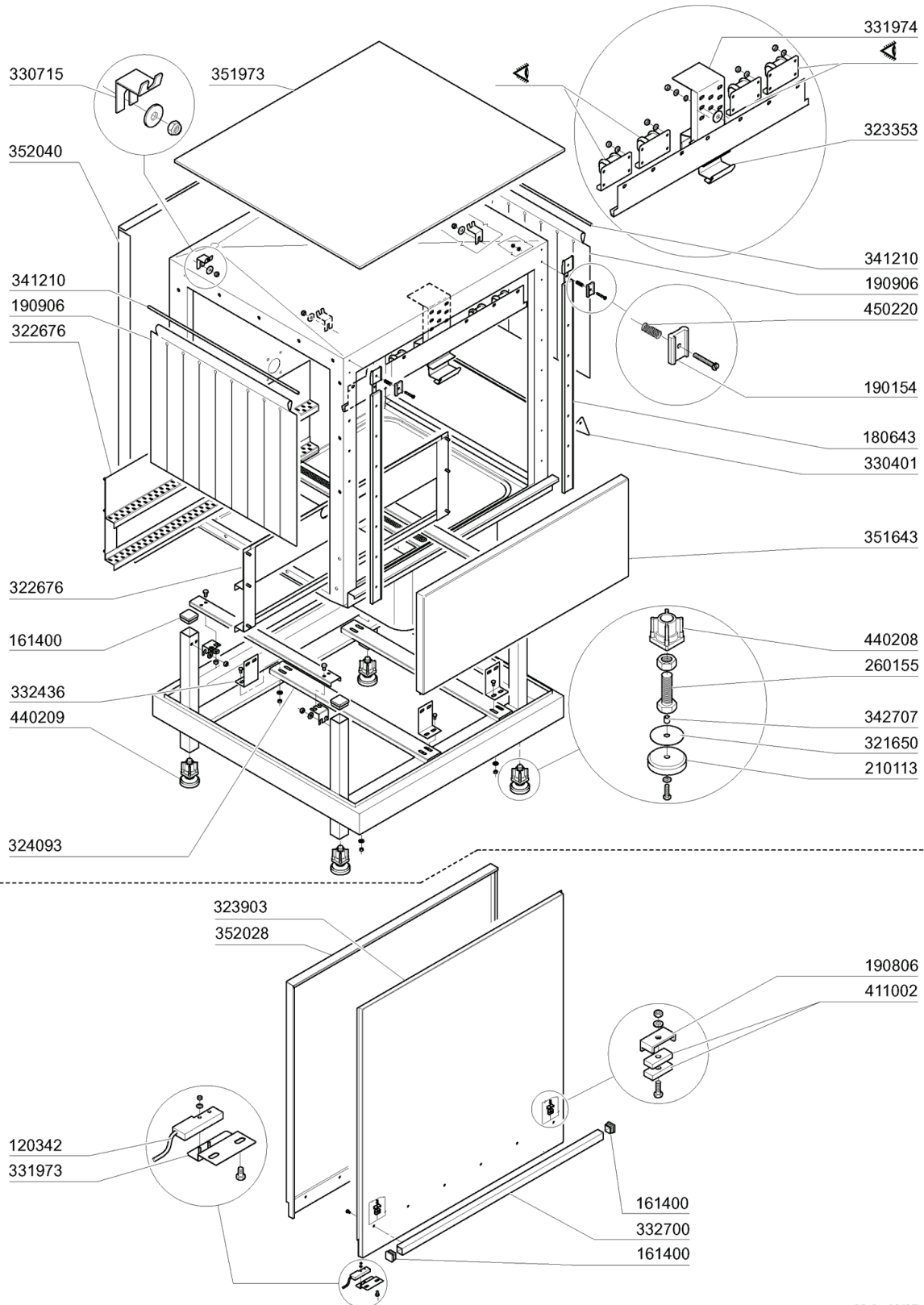

M.G. 10/07

3 - Prewash Assembly 900mm

CODE	DESCRIPTION
120342	DOR MAGNETIC SWITCH
161400	PLUG
180643	NE DOOR RAIL WITH BRAKE
190154	BRAKE
190806	MAGNET HOUSING
190906	CURTAIN IN/OUT 620X480
210113	FOOT NE/2
260155	SCREW M16X80 ST.STEEL
321650	PLATE FOR FOOT
322676	WASH GUIDE 900 NE/2
323353	SUPPORT
323903	INSULATED DOOR 900 NL2
324093	SUPPORT
330401	SPARTIACQ.SEMPL.VASCA NE BTM
330715	UPPER BRACKET CURTAIN SNL-SE
331973	DOOR MICRO SWITCH BRACKET
331974	SUPPORT FOR DOOR HOOK
332436	BRACKET
332700	DOOR HANDLE 900 NL2
341210	CURTAIN SHAFTS N 2S GM
342707	SPACER
351643	PANEL 900MM NE
351973	UPPER PANEL FOR HOOD 900
352028	INSULATED PANEL 900
352040	.
411002	PERMANENT MAGNET 24X12
440208	FOOT INSERT
440209	COMPLETE FOOT NE
450220	SPRING

4 - Prewash Assembly 900mm

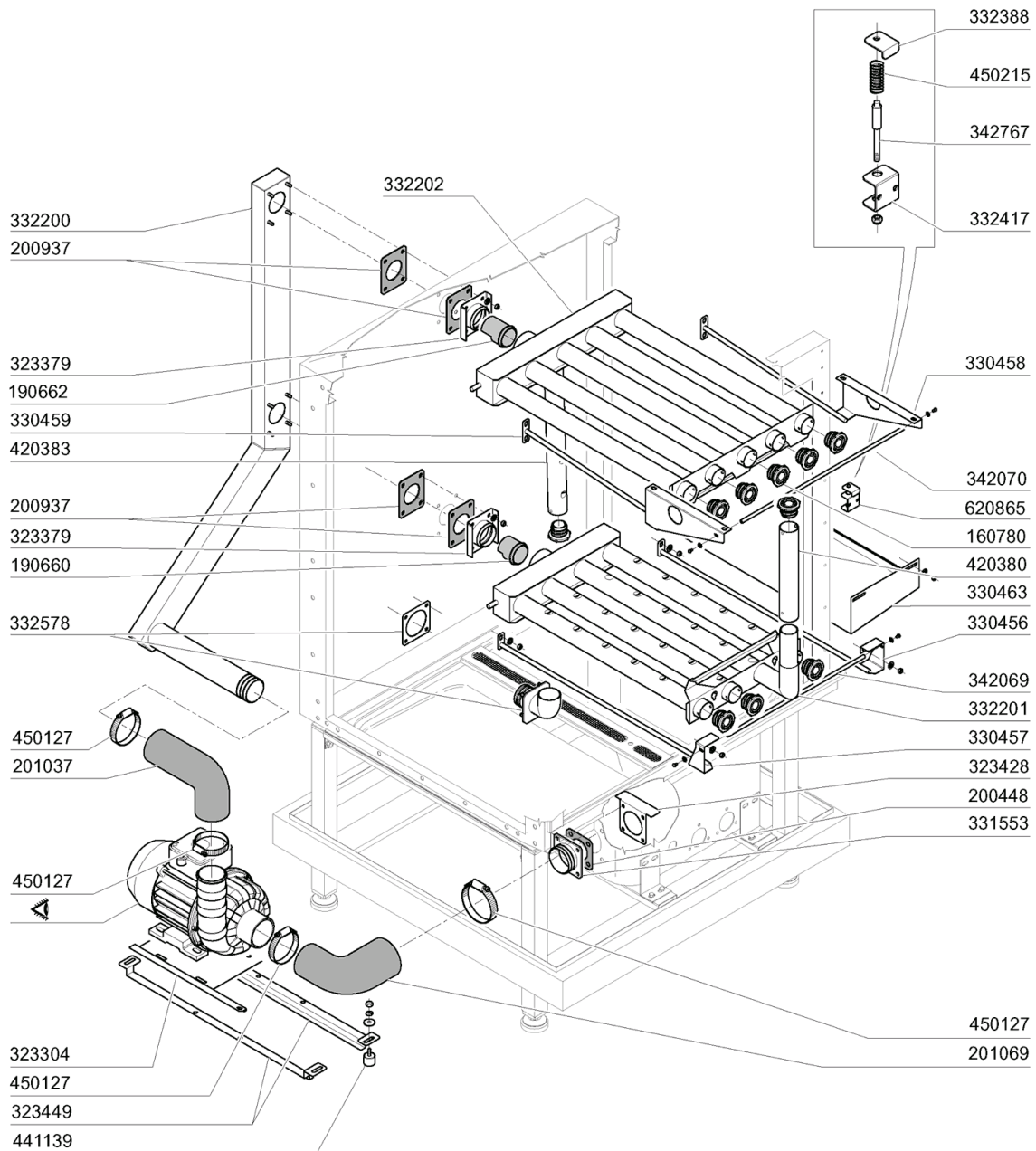

M.G. 10/07

4 - Prewash Assembly 900mm

CODE	DESCRIPTION
160780	PLUG FOR WASH ARM
190660	BUSH
190662	BUSH
200448	GASKET 100X100X3 HOLE D.76
200937	GASKET F.LOWER WASH ARM
201037	OUTLET HOSE
201069	INLET HOSE
323304	SUPPORT
323379	HOOK FOR WASH MANIFOLD
323428	FILTER BRACKET
323449	SUPPORT
330456	RIGHT BRACKET
330457	LEFT BRACKET
330458	RIGHT BRACKET
330459	LEFT BRACKET
330463	PANEL
331553	INLET ELBOW FOR NG-GL WASH PUM
332200	WASH COLUMN
332201	CONNECTION ELBOW F.LOWER WASH
332202	CONNECTION ELBOW F.UPPER WASH
332388	BRACKET
332417	BRACKET
332578	OVERFLOW
342069	LOWER WASH ARM PIN
342070	UPPER WASH ARM PIN
342767	PIN
420380	SIDE WASH ARM
420383	SIDE ARM
441139	VIBRATION-DAMPING FEET 25X20X6
450127	CLAMP FE ZN. 68-85 H=12,2
450215	SPRING F.SWITCH ROD R/B41-11-2
620865	WASH ARM SUPPORT NE02

5 - Prewash Tank 900mm

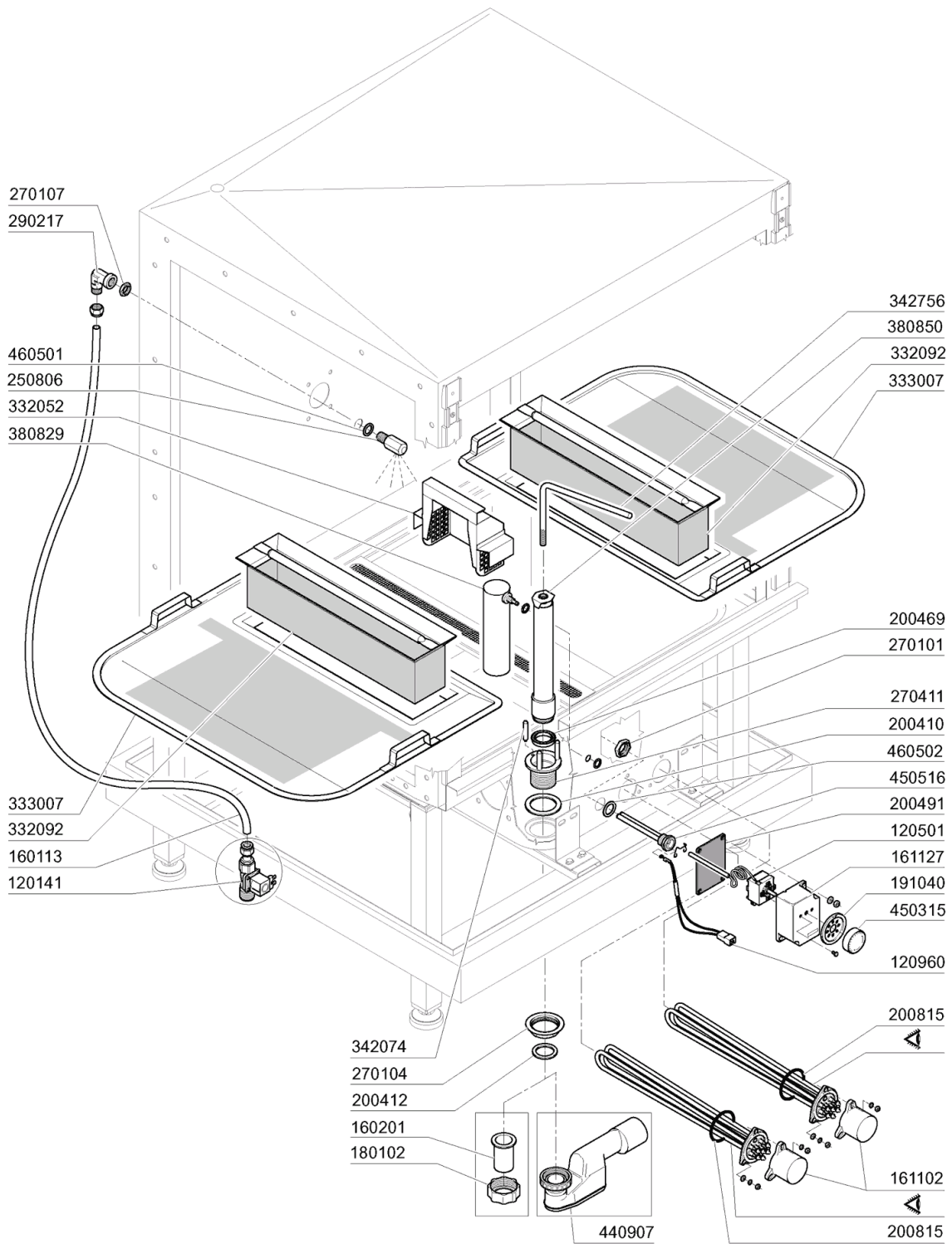

M.G. 10/07

5 - Prewash Tank 900mm

CODE	DESCRIPTION
120141	SOLE.N.VALVE METAL.328000 D.1/2
120501	THERMOSTAT 30/90°C
120960	PROBE C-G
160113	TUBE IN POL. RETIC. 12 EST
160201	ELBOW F.TANK INLET MOPLN
161102	ELEMENT COVER MOPL.
161127	BOX FOR THERMOSTAT
180102	DRAIN PIPE NUT 1"1/2 F45-55
191040	FRAME F.THERMOSTAT KNOB
200410	DRAIN OUTL.WASH.1 1/2"65X47X2
200412	GASKET DRAIN 11/2" 45X33X3
200469	STAND PIPE O RING 45X35,5X7
200491	BACK GASKET OF THERMOSTAT BOX
200815	O-RING F. HEAT.ELEM.
250806	TANK FILL HOSE CLAMP - AC/ACR
270101	HEXAGON LOCK NUT 1/2"
270104	LOCK NUT 1" 1/2
270107	BRASS LOCK NUT 3/8" FL803
270411	DRAIN OUTLET F. PREWASH/ECOR.
290217	HOSE CLAMP ELBOW 12X3/8" TYPE
332052	SUCTION FILTER NG2
332092	STRAINER FOR PREWASH TANK ACS
333007	STRAINER
342074	PIN
342756	ROD
380829	ST/ST AIR CHAMBER FOR NG-NE
380850	OVERFLOW PIPE
440907	SIPHON 1"1/2
450315	KNOB F. THERMOSTAT 90°
450516	THERMOSTAT SHIELD FOR 2 TERMOS
460501	GASKET 24X17X2
460502	GASKET 30X21X2

6 - Wash Hood 900mm

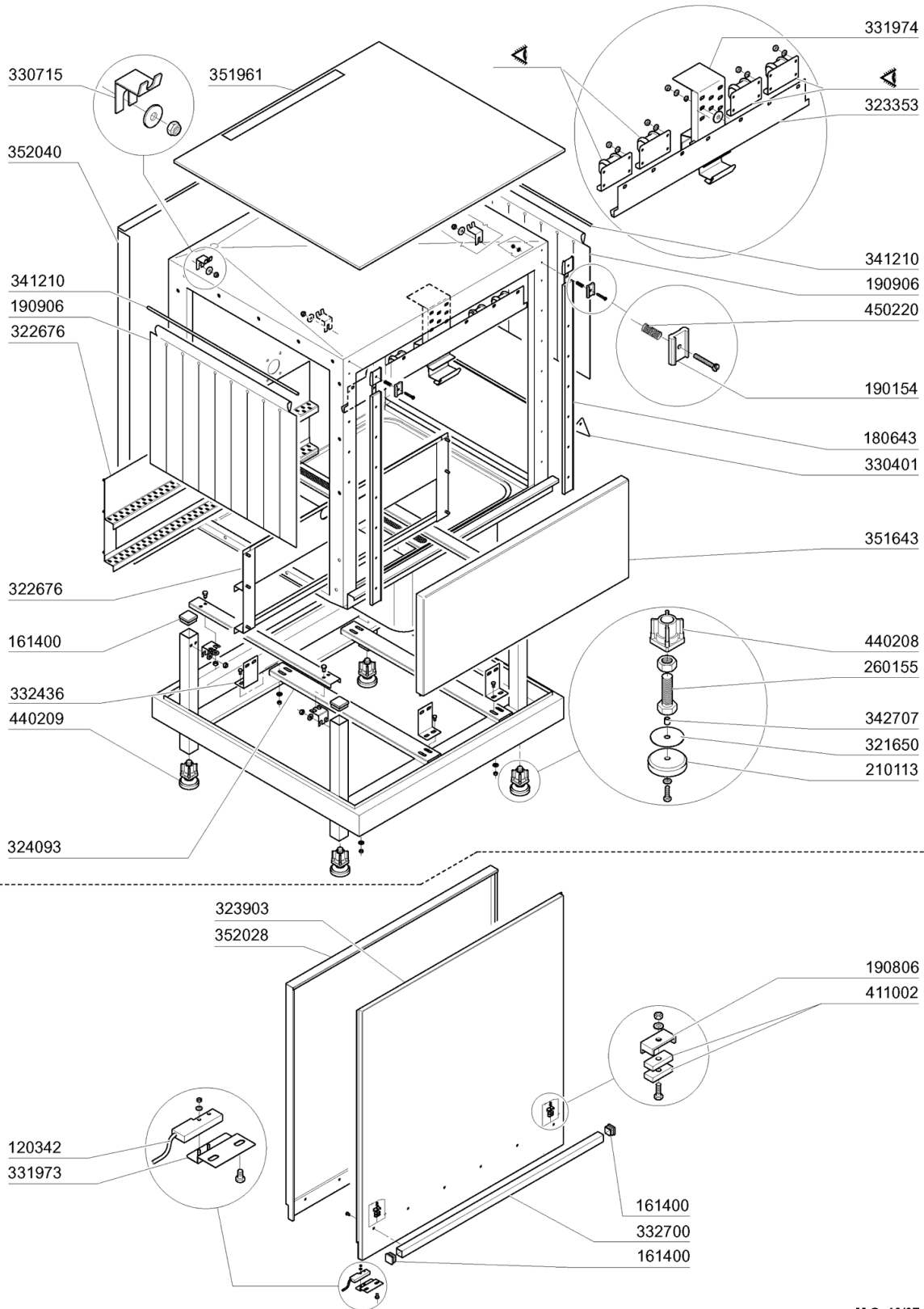

M.G. 10/07

6 - Wash Hood 900mm

CODE	DESCRIPTION
120342	DOR MAGNETIC SWITCH
161400	PLUG
180643	NE DOOR RAIL WITH BRAKE
190154	BRAKE
190806	MAGNET HOUSING
190906	CURTAIN IN/OUT 620X480
210113	FOOT NE/2
260155	SCREW M16X80 ST.STEEL
321650	PLATE FOR FOOT
322676	WASH GUIDE 900 NE/2
323353	SUPPORT
323903	INSULATED DOOR 900 NL2
324093	SUPPORT
330401	SPARTIACQ.SEMPL.VASCA NE BTM
330715	UPPER BRACKET CURTAIN SNL-SE
331973	DOOR MICRO SWITCH BRACKET
331974	SUPPORT FOR DOOR HOOK
332436	BRACKET
332700	DOOR HANDLE 900 NL2
341210	CURTAIN SHAFTS N 2S GM
342707	SPACER
351643	PANEL 900MM NE
351961	UPPER PANEL FOR HOOD 900
352028	INSULATED PANEL 900
352040	.
411002	PERMANENT MAGNET 24X12
440208	FOOT INSERT
440209	COMPLETE FOOT NE
450220	SPRING

7 - Wash tank 900mm

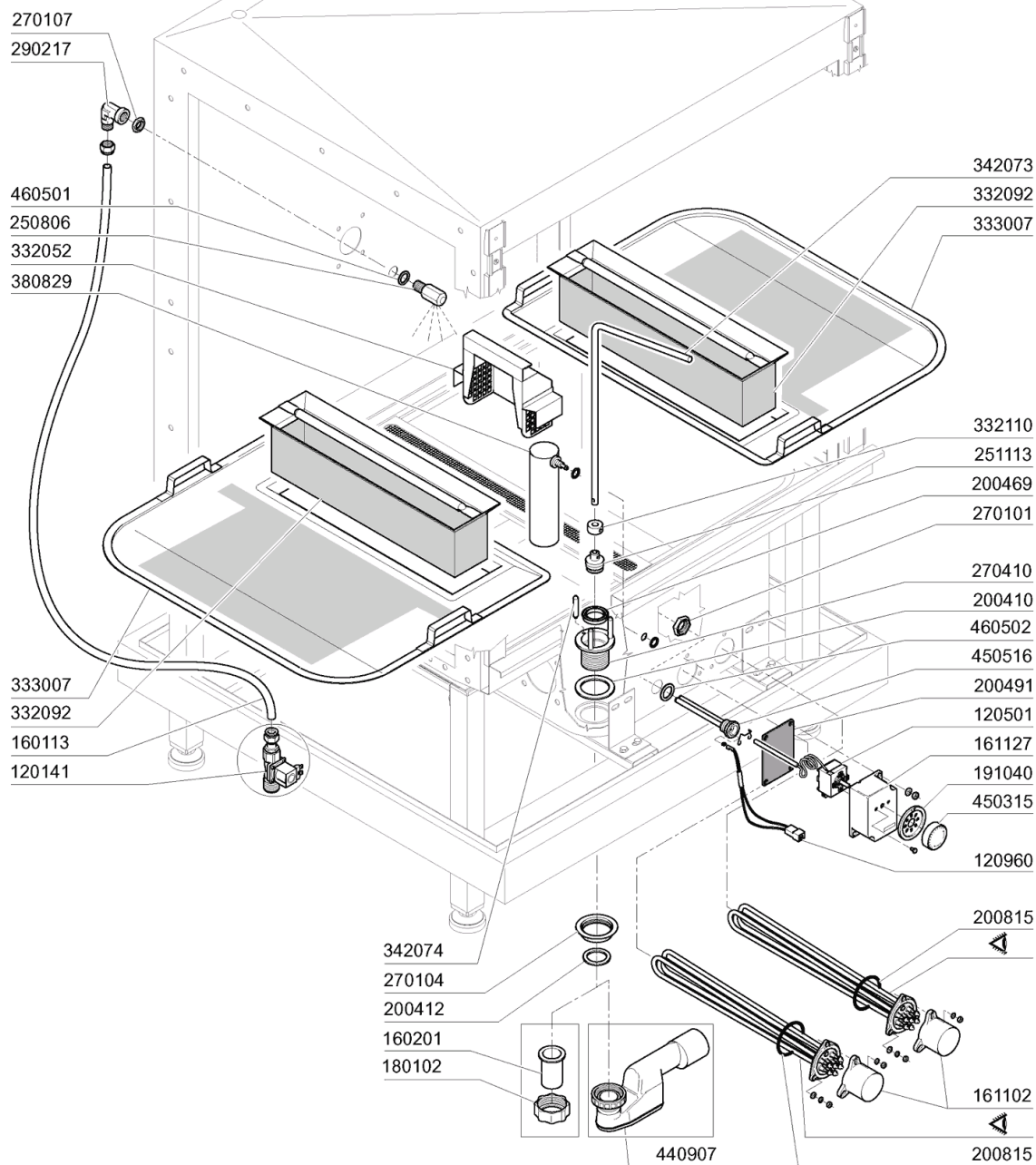

M.G. 10/07

7 - Wash tank 900mm

CODE	DESCRIPTION
120141	SOLE.N.VALVE METAL.328000 D.1/2
120501	THERMOSTAT 30/90ØC
120960	PROBE C-G
160113	TUBE IN POL. RETIC. 12 EST
160201	ELBOW F.TANK INLET MOPLN
161102	ELEMENT COVER MOPL.
161127	BOX FOR THERMOSTAT
180102	DRAIN PIPE NUT 1"1/2 F45-55
191040	FRAME F.THERMOSTAT KNOB
200410	DRAIN OUTL.WASH.1 1/2"65X47X2
200412	GASKET DRAIN 11/2" 45X33X3
200469	STAND PIPE O RING 45X35,5X7
200491	BACK GASKET OF THERMOSTAT BOX
200815	O-RING F. HEAT.ELEM.
250806	TANK FILL HOSE CLAMP - AC/ACR
251113	PLUG FOR DRAIN TANK
270101	HEXAGON LOCK NUT 1/2"
270104	LOCK NUT 1" 1/2
270107	BRASS LOCK NUT 3/8" FL803
270410	TANK DRAIN OUTLET
290217	HOSE CLAMP ELBOW 12X3/8" TYPE
332052	SUCTION FILTER NG2
332092	STRAINER FOR PREWASH TANK ACS
332110	CLAMPING PIECES
333007	STRAINER
342073	WASH ROD
342074	PIN
380829	ST/ST AIR CHAMBER FOR NG-NE
440907	SIPHON 1"1/2
450315	KNOB F. THERMOSTAT 90Ø
450516	THERMOSTAT SHIELD FOR 2 TERMOS
460501	GASKET 24X17X2
460502	GASKET 30X21X2

8 - Wash Assembly 900mm

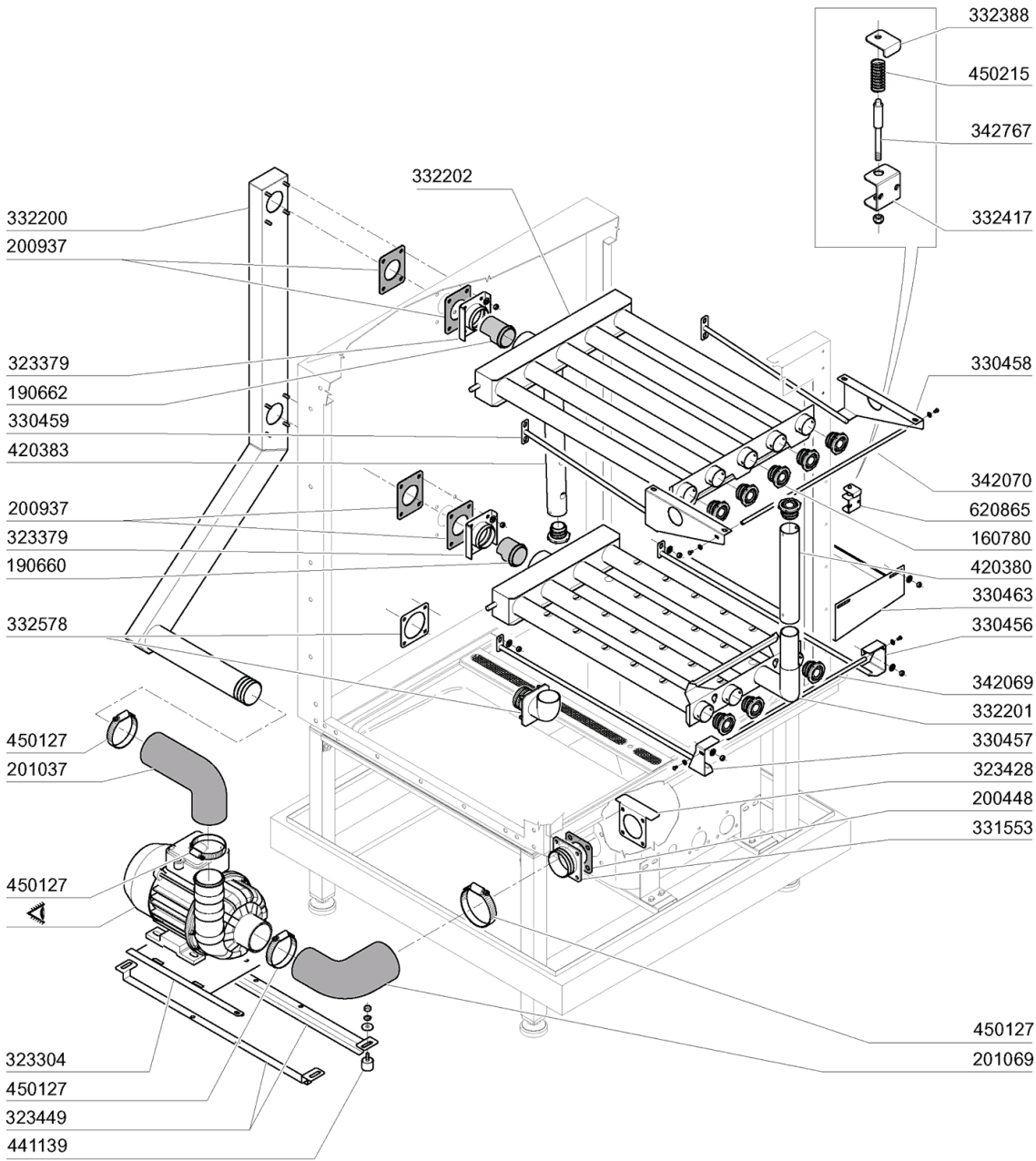

M.G. 10/07

8 - Wash Assembly 900mm

CODE	DESCRIPTION
160780	PLUG FOR WASH ARM
190660	BUSH
190662	BUSH
200448	GASKET 100X100X3 HOLE D.76
200937	GASKET F.LOWER WASH ARM
201037	OUTLET HOSE
201069	INLET HOSE
323304	SUPPORT
323379	HOOK FOR WASH MANIFOLD
323428	FILTER BRACKET
323449	SUPPORT
330456	RIGHT BRACKET
330457	LEFT BRACKET
330458	RIGHT BRACKET
330459	LEFT BRACKET
330463	PANEL
331553	INLET ELBOW FOR NG-GL WASH PUM
332200	WASH COLUMN
332201	CONNECTION ELBOW F.LOWER WASH
332202	CONNECTION ELBOW F.UPPER WASH
332388	BRACKET
332417	BRACKET
332578	OVERFLOW
342069	LOWER WASH ARM PIN
342070	UPPER WASH ARM PIN
342767	PIN
420380	SIDE WASH ARM
420383	SIDE ARM
441139	VIBRATION-DAMPING FEET 25X20X6
450127	CLAMP FE ZN. 68-85 H=12,2
450215	SPRING F.SWITCH ROD R/B41-11-2
620865	WASH ARM SUPPORT NE02

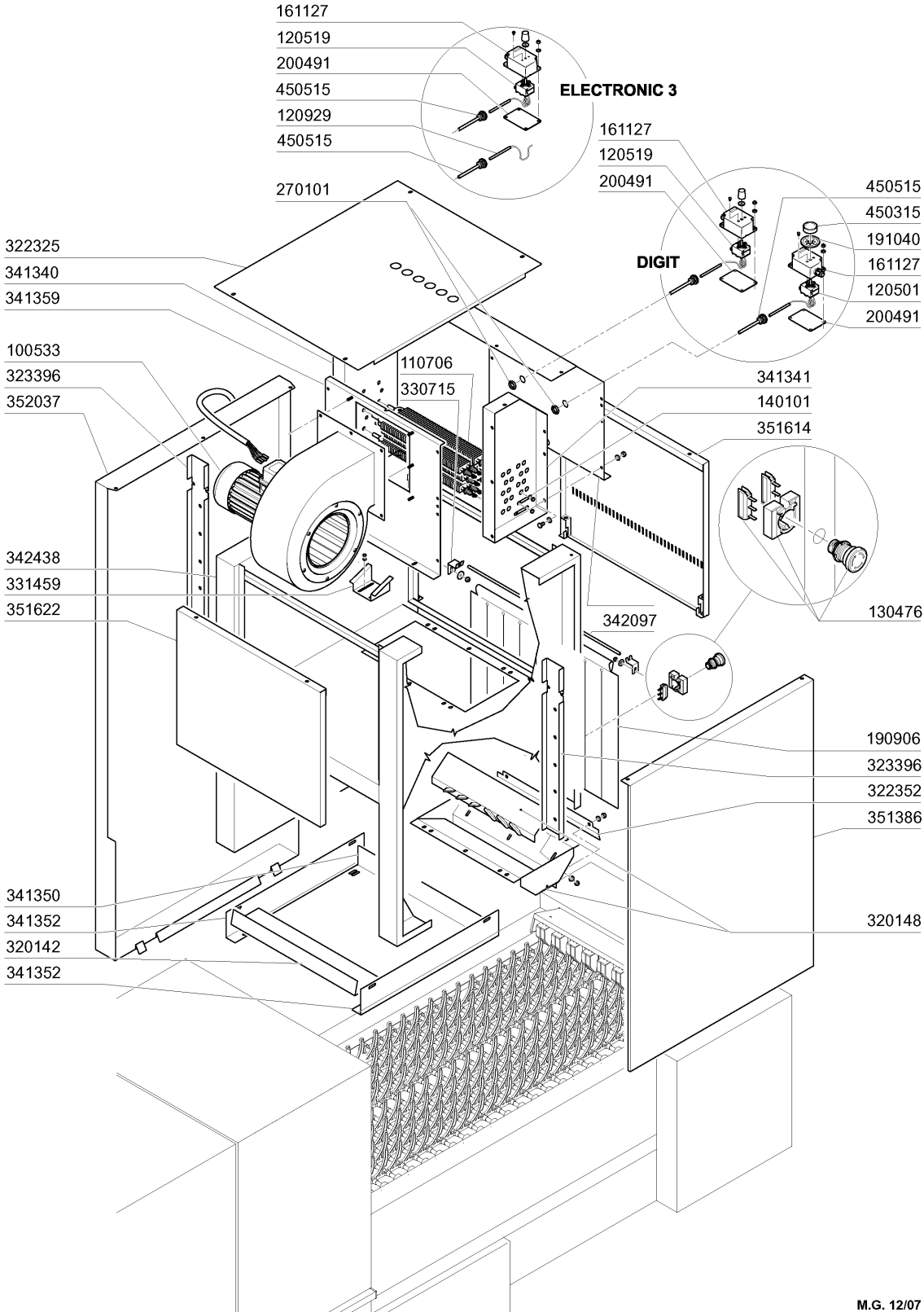

M.G. 12/07

9 - Blower Dryer 800

CODE	DESCRIPTION
100533	FAN HP 1 220-240-380-415V VRP2
110706	DRYER HEAT.ELEMENT 1500W 230V
120501	THERMOSTAT 30/90°C
120519	SECURITY THERMOSTAT 95-125°C
120929	PROBE 12 MT
130476	ROTATIVE EMERGENCY SWITCH
140101	BRASS CONNECT. PLATE HEAT.ELEM
161127	BOX FOR THERMOSTAT
190906	CURTAIN IN/OUT 620X480
191040	FRAME F.THERMOSTAT KNOB
200491	BACK GASKET OF THERMOSTAT BOX
270101	HEXAGON LOCK NUT 1/2"
320142	DEFLECTOR F. DRYER
320148	DEFLECTOR F. DRYER
322325	COVER
322352	BRACKET
323396	BRACKET FOR 800MM DRYER HOOD
330715	UPPER BRACKET CURTAIN SNL-SE
331459	BRACKET FOR DRYING VENTILATOR
341340	LEFT SUPPORT
341341	RIGHT SUPPORT
341350	PANEL
341352	SUPPORT
341359	FAN SUPPORT
342097	SHAFT
342438	800 MM DRYER HOOD
351386	800 MM DRYER SIDE PANEL
351614	PANEL
351622	PANEL
352037	800 MM DRYER BACK PANEL
450315	KNOB F. THERMOSTAT 90°C
450515	STAINL.ST.SHIELD FOR 1 THERMOS

10 - Blower Dryer hood 1000

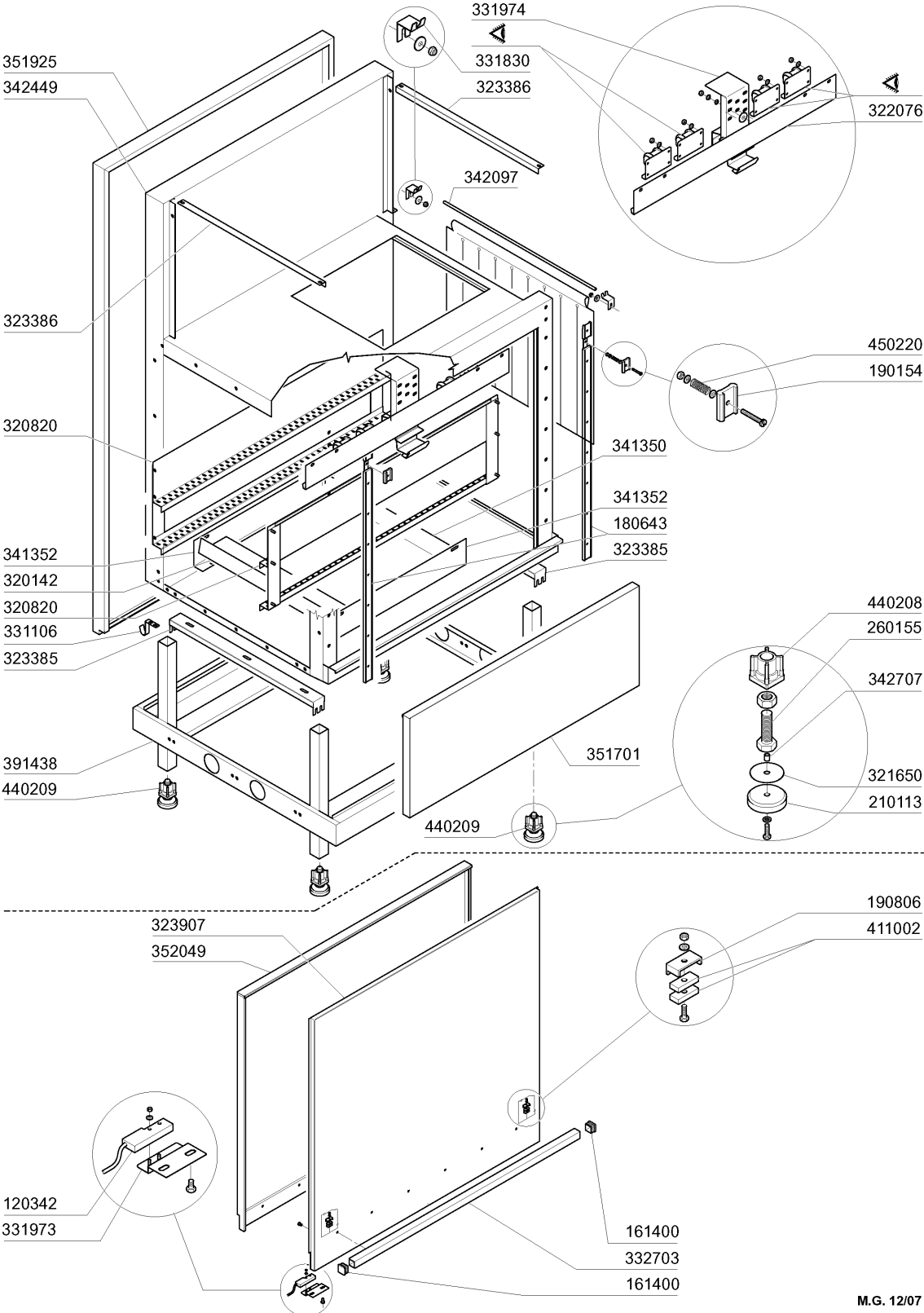

M.G. 12/07

10 - Blower Dryer hood 1000

CODE	DESCRIPTION
120342	DOR MAGNETIC SWITCH
161400	PLUG
180643	NE DOOR RAIL WITH BRAKE
190154	BRAKE
190806	MAGNET HOUSING
210113	FOOT NE/2
260155	SCREW M16X80 ST.STEEL
320142	DEFLECTOR F. DRYER
320820	WASH 1000 GUIDE
321650	PLATE FOR FOOT
322076	SUPPORT
323385	SUPPORT
323386	SUPPORT
323907	1000 DRYER DOOR
331106	SUPPORT.HOOK F.UPPER RINSE N-S
331830	BRACKET FOR CURTAIN
331973	DOOR MICRO SWITCH BRACKET
331974	SUPPORT FOR DOOR HOOK
332703	DOOR HANDLE 1000 NL2
341350	PANEL
341352	SUPPORT
342097	SHAFT
342449	1000 MM DRYER HOOD
342707	SPACER
351701	PANEL 1000
351925	PANEL
352049	INSULATED PANEL 1000
391438	HOOD
411002	PERMANENT MAGNET 24X12
440208	FOOT INSERT
440209	COMPLETE FOOT NE
450220	SPRING

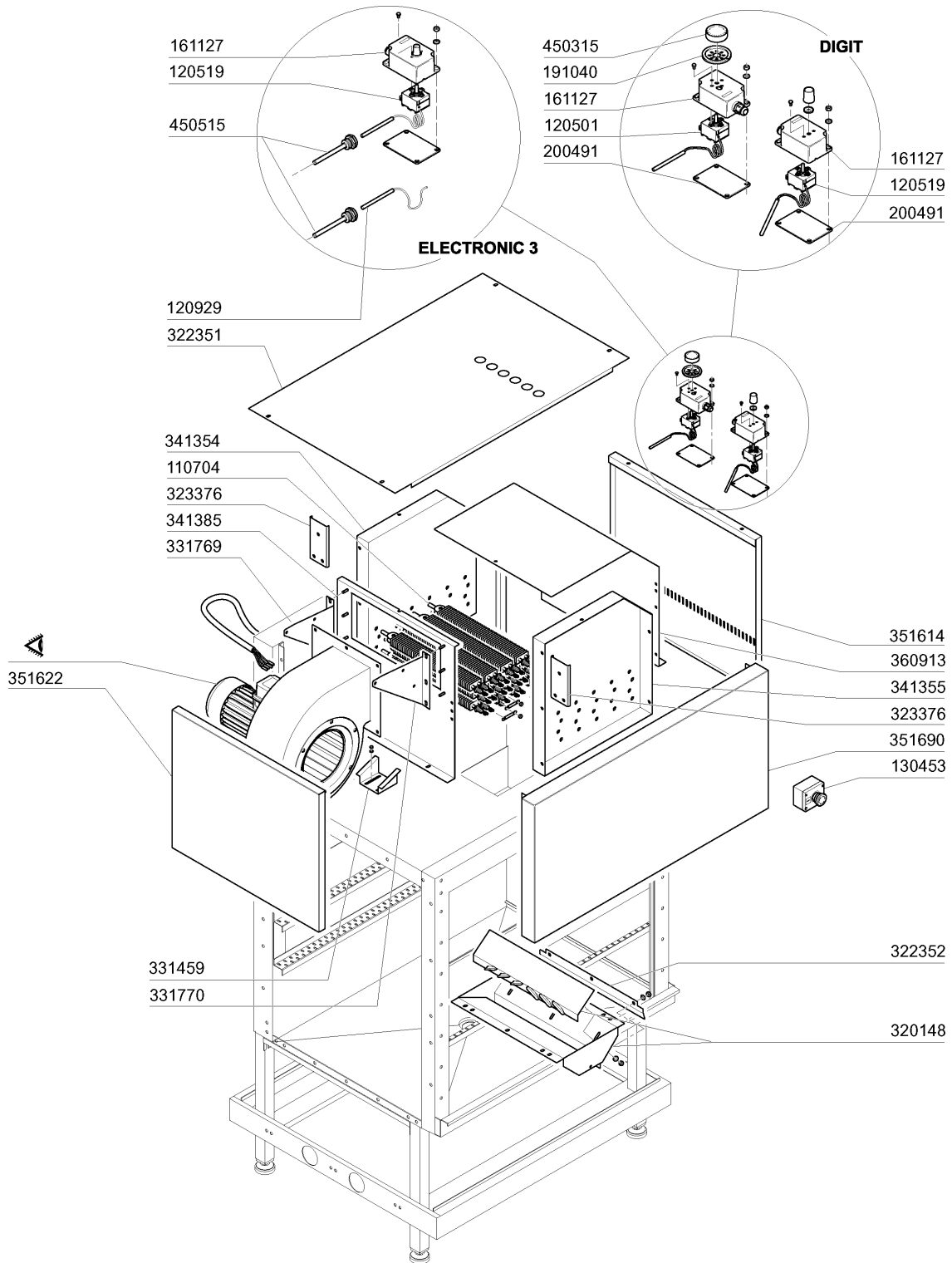

11 - Blower Dryer 1000

CODE	DESCRIPTION
110704	HEAT.ELEMENT/DRYING 1000W 220V
120501	THERMOSTAT 30/90ØC
120519	SECURITY THERMOSTAT 95-125Ø
120929	PROBE 12 MT
130453	EMERGENCY RED PUSH BUTTON
161127	BOX FOR THERMOSTAT
191040	FRAME F.THERMOSTAT KNOB
200491	BACK GASKET OF THERMOSTAT BOX
320148	DEFLECTOR F. DRYER
322351	COVER
322352	BRACKET
323376	BRACKET
331459	BRACKET FOR DRYING VENTILATOR
331769	ZIEHL FAN SUPPORT
331770	ZIEHL FAN SUPPORT
341354	RIGHT SUPPORT FOR DRYER 18KW 1
341355	LEFT SUPPORT FOR DRYER 18KW 10
341385	DRYER FAN SUPPORT FOR NE MACHI
351614	PANEL
351622	PANEL
351690	FRONT PANEL 1000
360913	BACK PANEL 1000MM NE XL
450315	KNOB F. THERMOSTAT 90Ø
450515	STAINL.ST.SHIELD FOR 1 THERMOS

12 - Rinse Hood

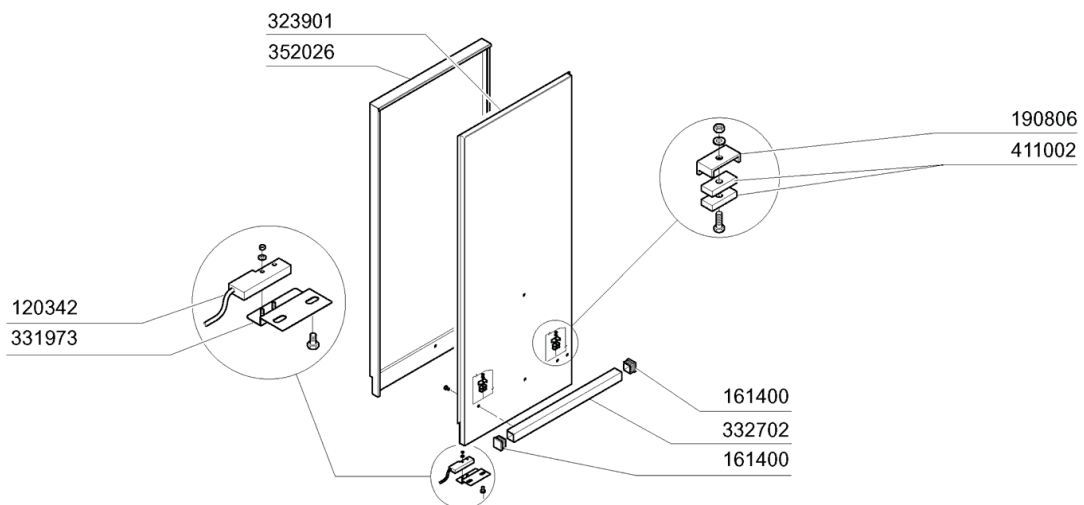
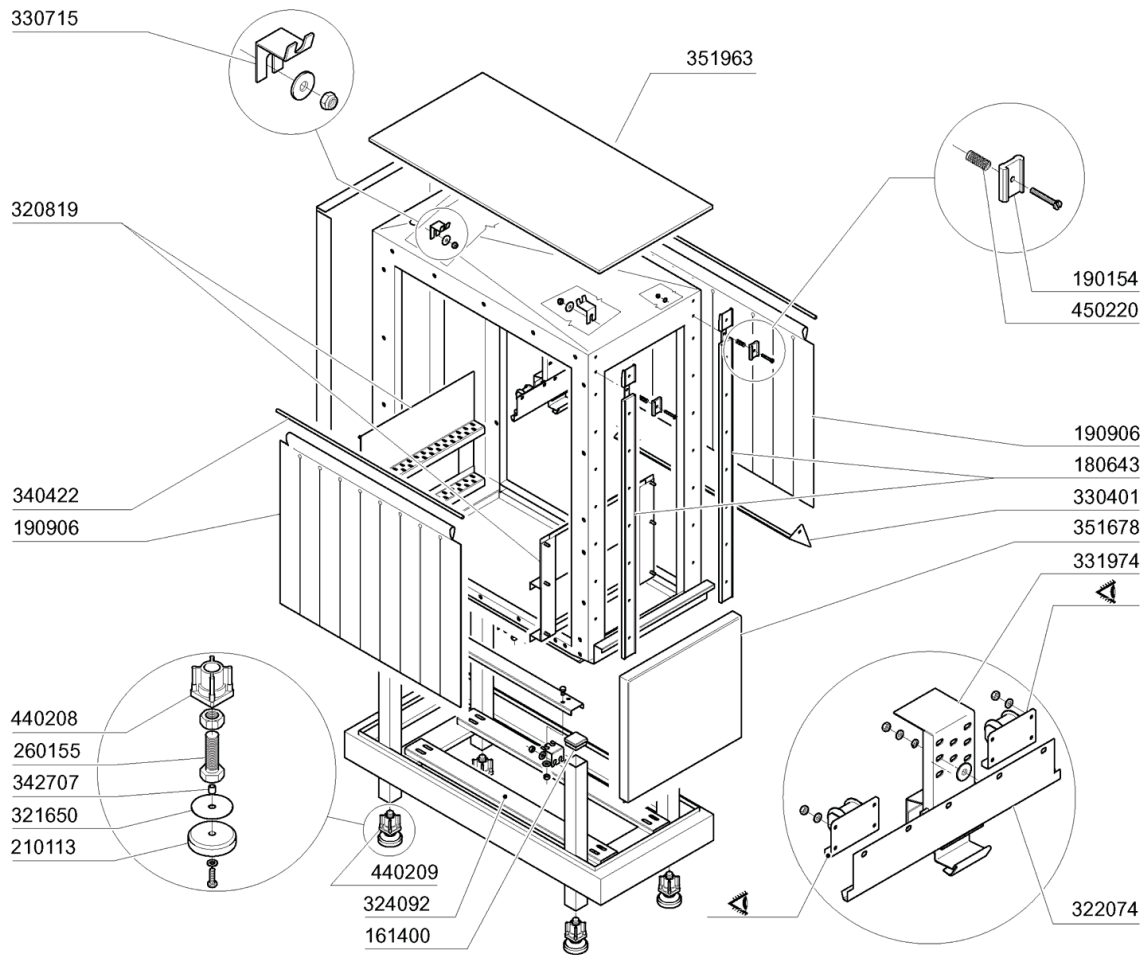

M.G. 10/07

12 - Rinse Hood

CODE	DESCRIPTION
120342	DOR MAGNETIC SWITCH
161400	PLUG
180643	NE DOOR RAIL WITH BRAKE
190154	BRAKE
190806	MAGNET HOUSING
190906	CURTAIN IN/OUT 620X480
210113	FOOT NE/2
260155	SCREW M16X80 ST.STEEL
320819	RINSE 400 NE GUIDE
321650	PLATE FOR FOOT
322074	SUPPORT
323901	INSULATED DOOR 400 NL2
324092	SUPPORT
330401	SPARTIACQ.SEMPL.VASCA NE BTM
330715	UPPER BRACKET CURTAIN SNL-SE
331973	DOOR MICRO SWITCH BRACKET
331974	SUPPORT FOR DOOR HOOK
332702	DOOR HANDLE 400 NL2
340422	SHAFT FOR CURTAIN AC-ACR
342707	SPACER
351678	FRONT PANEL 400
351963	UPPER PANEL FOR HOOD 400
352026	INSULATED PANEL 400
411002	PERMANENT MAGNET 24X12
440208	FOOT INSERT
440209	COMPLETE FOOT NE
450220	SPRING

13 - Rinse assembly

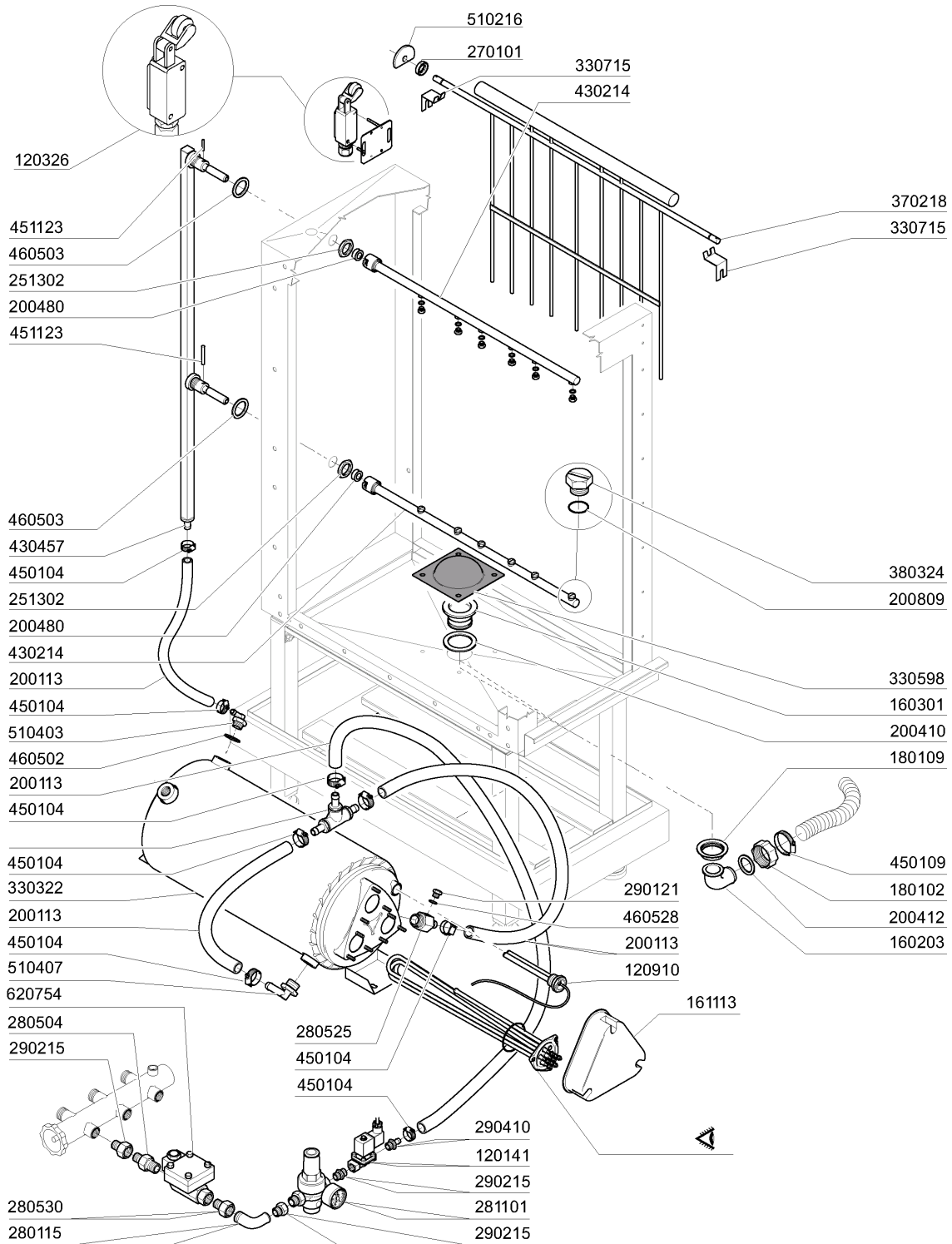

M.G. 10/07

13 - Rinse assembly

CODE	DESCRIPTION
120141	SOLE.N.VALVE METAL.328000 D.1/2
120326	MICRO SWITCH FD 102
120910	ELECTRONIC TOUCH PAD CONTROLS
160203	ELBOW 1"1/2 N-S-F-C /DRAIN
160301	DRAIN OUTLET 1"1/2 C-S-N
161113	ELMENT COVER BLACK
180102	DRAIN PIPE NUT 1"1/2 F45-55
180109	LOCK NUT 1 1/2"
200113	RUBBER HOSE 12 X 22
200410	DRAIN OUTL.WASH.1 1/2"65X47X2
200412	GASKET DRAIN 11/2" 45X33X3
200480	GASKET F. RINSE CONNECT.
200809	OR GASKET 1,78X8,73X12,29
251302	S/S LOCK NUT 3/4" AC-ACR
270101	HEXAGON LOCK NUT 1/2"
280115	ELL 1/2"
280504	MANIFOLD CONN.HOSE
280525	NIPPLE
280530	CONNECT.3/4"X3/8"
281101	3/4" ADJ VALVE C/W GAUGE
290121	BRASS PLUG 1/8"
290215	1/2"BSP M/F UNION BRASS
290410	NIPPLE 1/2"
330322	INSULATED BOILER D.230 N/S
330598	ECORINSE FILTER
330715	UPPER BRACKET CURTAIN SNL-SE
370218	RINSE ECONOMISER FOR NE02
380324	RINSE JETS 52,5 80Ø OV1/8"
430214	RINSE ARM NE02
430457	RINSE COLUMN NE02
450104	CLAMP FE ZN H=12,5 15-24
450109	CLAMP 50-65
451123	ELASTIC PIN 4X16
460502	GASKET 30X21X2
460503	SEALING WASHER 38X27X2(3/4)
460528	GASKET 15X10X2 FOR RINSE NIPPE
510216	N RINSE GATE ECCENTRE
510403	CONNECT.HOSE 90Ø1/2"X12
510407	NIPPLE FOR BOILER N S
620754	FLUX CONTROL

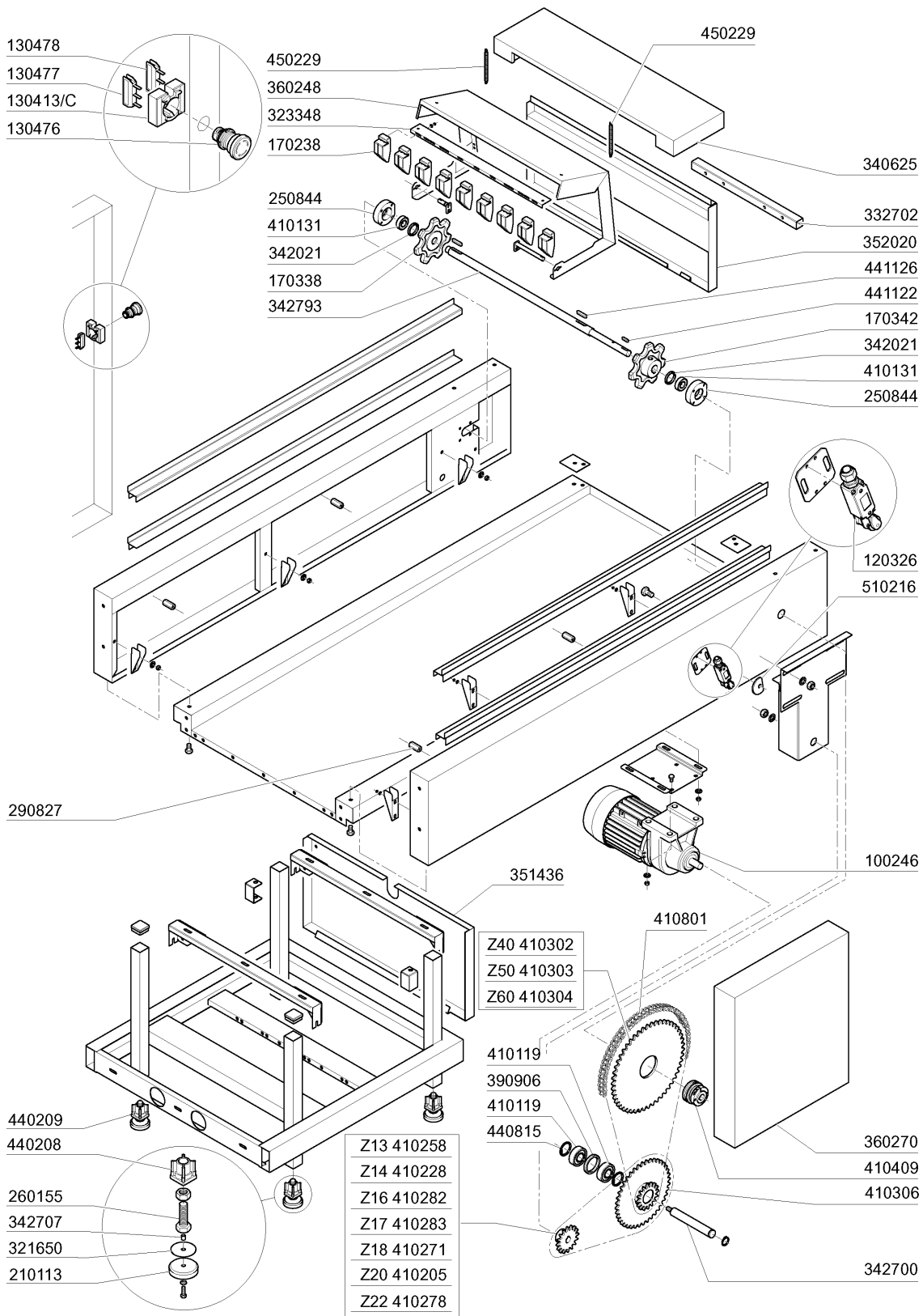

M.G. 01/08

CODE	DESCRIPTION
100246	DRIVE KW 0,1-0,15 380/3
120326	MICRO SWITCH FD 102
130413/C	SUPPORT FOR ABB SWITCH
130476	ROTATIVE EMERGENCY SWITCH
130477	CONTACT NC
130478	CONTACT N.O.
170238	PEG END RUN ARM NE/2
170338	PLASTIC PINION Z7 P60
170342	PINION
210113	FOOT NE/2
250844	SUPPORT
260155	SCREW M16X80 ST.STEEL
290827	SPACER NG-LVP1001
321650	PLATE FOR FOOT
323348	SUPPORT FOR FINGERS
332702	DOOR HANDLE 400 NL2
340625	EXIT TABLE COVER
342021	SPACER
342700	PIN
342707	SPACER
342793	DRIVE UNIT NL2
351436	SIDE PANEL
352020	FRONT PANEL
360248	COVER
360270	BCK COVER CHANNEL
390906	SPACER
410119	RADIAL BEARING 32X15X9
410131	S/S BALL BEARING 6004 2RS 20X4
410205	PINION Z 14 - 1/2
410228	TURNED PINION Z14-1/2"-D.19
410258	PINION Z13-1/2" D19
410271	PINION Z18 1/2-D.19
410278	PINION Z22 1/2 D19
410282	PINION Z16-1/2-D.19
410283	PINION Z17-1/2-D.19
410302	CROWN DISCS 40T 1/2" PITCH
410303	CROWN DISCS 50T 1/2" PITCH
410304	CROWN DISCS 60T 1/2"PITCH
410306	GROUP CROWN-SPROCKET Z14/40
410409	TORQUE LIMITER LC2
410801	DRIVE CHAIN 1/2" N-S
440208	FOOT INSERT
440209	COMPLETE FOOT NE
440815	INTERN.SEAL RING D.32
441122	DRIVE SHAFT KEY 6X6X25 UNI 660
441126	DRIVE SHAFT KEY 8X7X40
450229	STAINL.ST SPRING LIMIT SWITCH
510216	N RINSE GATE ECCENTRE

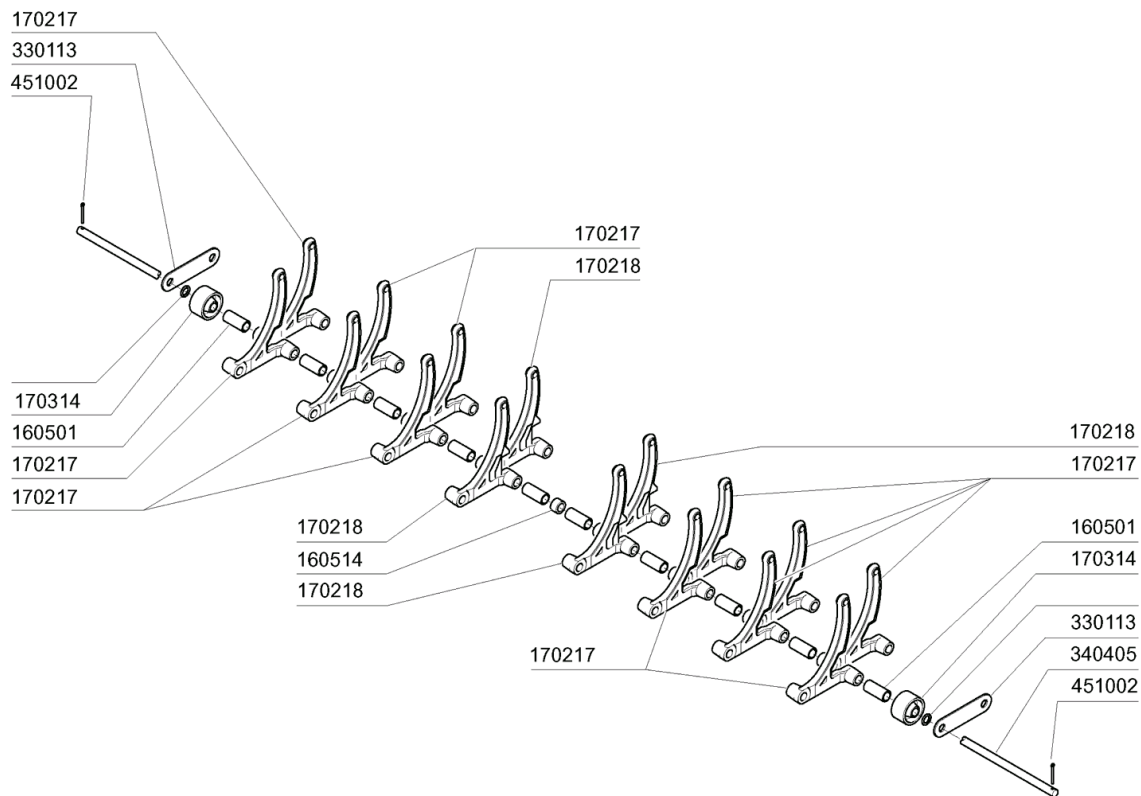
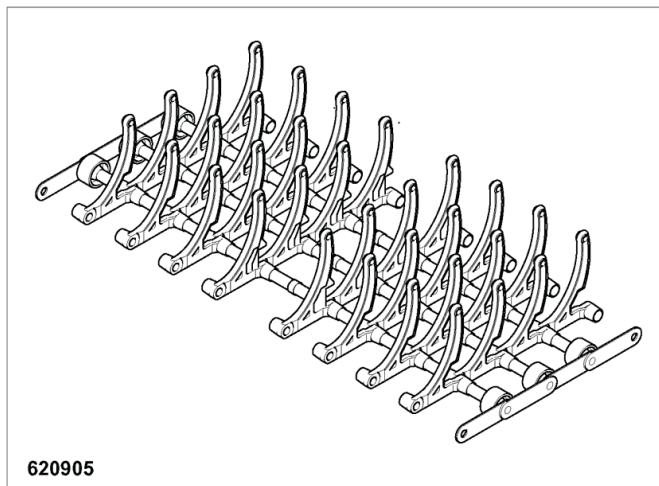

15 - Conveyor

CODE	DESCRIPTION
160501	SPACER FLIGHT D.9X25 CONVEYOR
160514	SPACER 7,9 108378 MOP
170217	FINGER FOR BELT 60MM
170218	CENTRAL FINGER 60MM CONVEYOR B
170314	GRAY BELTWHEEL N
330113	LINKS
340405	SHAFT FOR BELTN D.8X611
451002	COTTER PIN STAINL.ST. D2X12
620905	BELT NL2 P.60

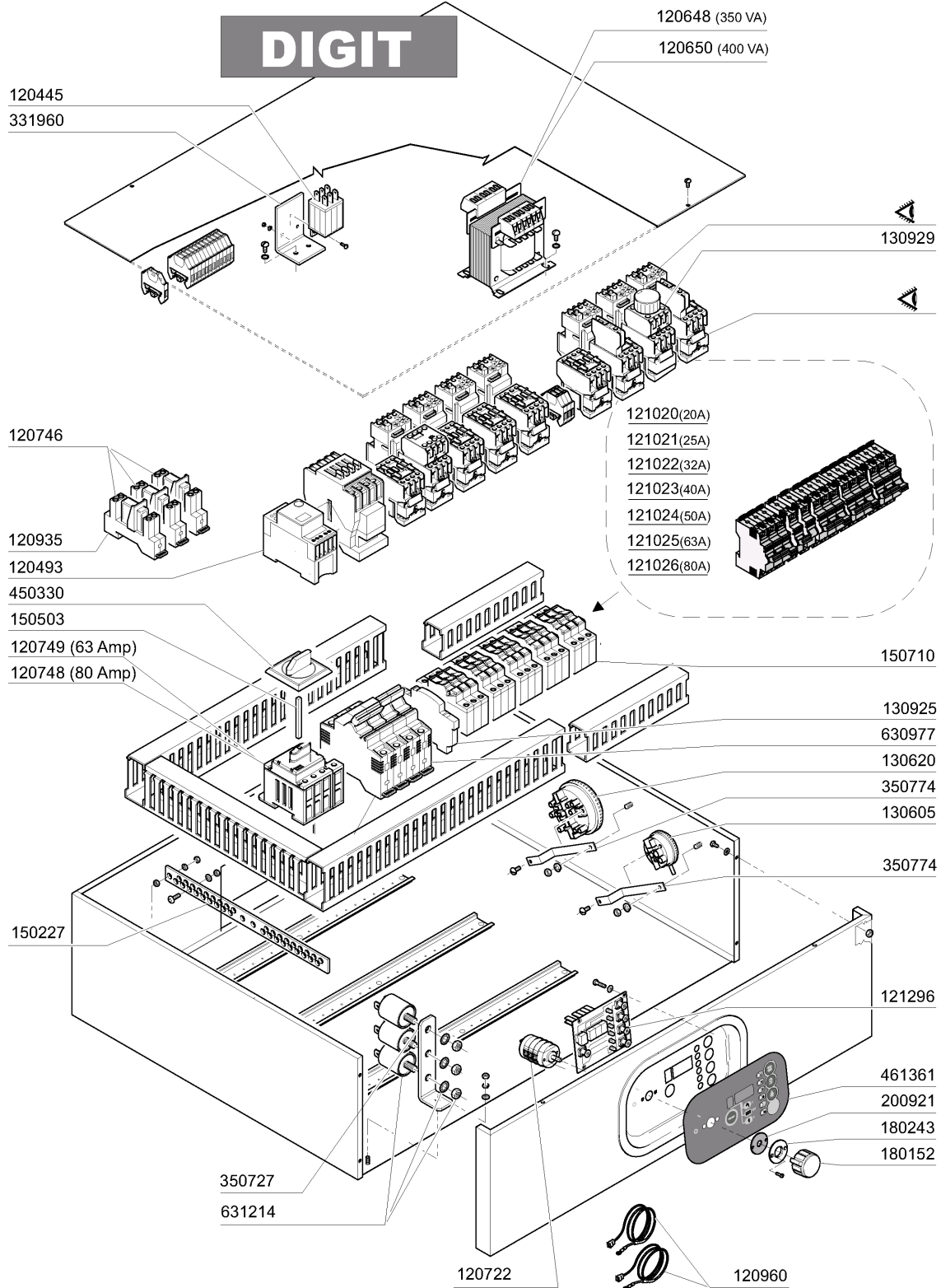

M.G. 10/07

16 - Control Box

CODE	DESCRIPTION
120445	AUXILIARY RELAY S.B2/3 24V
120493	RELAY 130180240000
120648	TRANSFORMER 250VA225-240-380-4
120650	TRANSFORMER 400VA225-240-380-4
120722	6 POLE SWITVH 2 POSITIONS
120746	SELECTOR WITH LIGHT RM650R
120748	MAINSWITCH 80A 4P
120749	MAINSWITCH 63A 4P
120935	SUPPORT
120960	PROBE C-G
121020	CIRCUIT BREAKER 20A
121021	CIRCUIT BREAKER 25A
121022	CIRCUIT BREAKER 32A
121023	CIRCUIT BREAKER 40A
121024	CIRCUIT BREAKER 50A
121025	CIRCUIT BREAKER 63A
121026	MAGN.SWITCH 80A
121296	ELECTRONIC CONTROL PANEL
130605	PRESSURE SWITCH 50-30 1 LEVEL
130620	PRESSURE SWITCH 3 LEVEL 50-30/
130925	CONTACT FOR CIRCUIT BREAKER
130929	CONTACT ABB 1NO/1NC 30"
150227	BRACKET
150503	EXTENTION FOR MAIN SWITCH
150710	FUSE CARRIER 10,3X38 ART.21401
180152	KNOB
180243	FLANGE
200921	GASKET
331960	BRACKET
350727	BRACKET
350774	BRACKET
450330	KNOB FOR MAIN SWITCH
461361	PLATE ACS101-242 DIGIT
630977	COIL FOR CIRCUIT BREAKER 24V
631214	ANTI-NOISE FILTER 4011135007 3

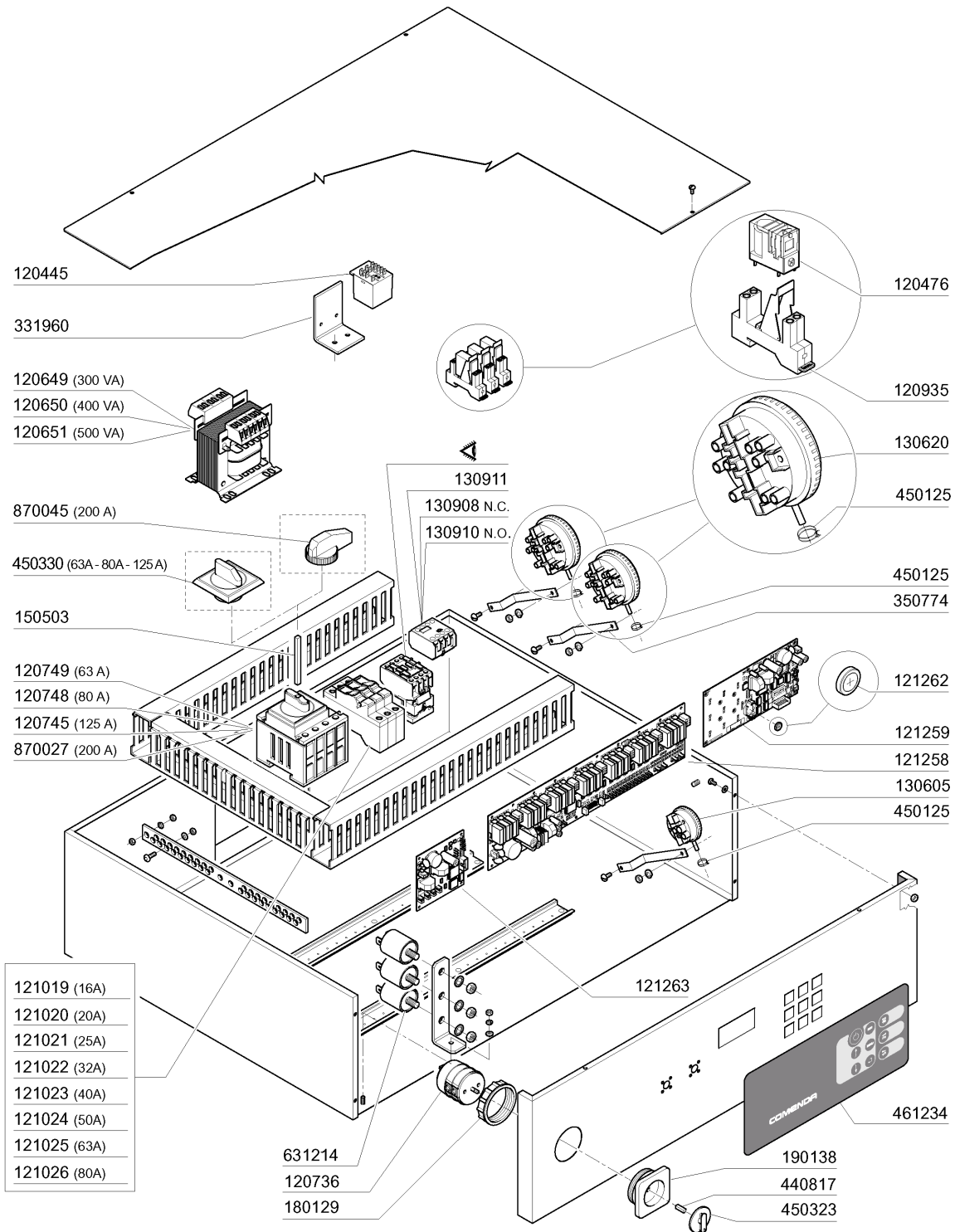

17 - Control Box

CODE	DESCRIPTION
120445	AUXILIARY RELAY S.B2/3 24V
120476	RELAY 16A 24V
120649	TRANSFORMER 300VA225-240-380-4
120650	TRANSFORMER 400VA225-240-380-4
120651	TRANSFORMER 500VA225-240-380-4
120736	4 POLE MAIN SWITCH 25A 500V
120745	MAIN SWITCH 4 POLE 125A
120748	MAINSWITCH 80A 4P
120749	MAINSWITCH 63A 4P
120935	SUPPORT
121019	MAGNETOT.SWITCH S253C16
121020	CIRCUIT BREAKER 20A
121021	CIRCUIT BREAKER 25A
121022	CIRCUIT BREAKER 32A
121023	CIRCUIT BREAKER 40A
121024	CIRCUIT BREAKER 50A
121025	CIRCUIT BREAKER 63A
121026	MAGN.SWITCH 80A
121258	MAIN PCB E3
121259	KEYBOARD PCB
121262	LITHIUM BATTERY 3V.CR2450N
121263	HPS BOARD
130605	PRESSURE SWITCH 50-30 1 LEVEL
130620	PRESSURE SWITCH 3 LEVEL 50-30/
130908	AUXILIARY CONTACT LA1 DO2 A65
130910	CONTACT LA1 D20 A65
130911	CONTACT LA1 D40 A65
150503	EXTENTION FOR MAIN SWITCH
180129	NUT FOR MAIN SWITCH SUPPORT
190138	SUPPORT
331960	BRACKET
350774	BRACKET
440817	SNAP RING LSCB/1853/17/00
450125	ELASTIC CLAMP D. 10,4X9,8
450323	KNOB FOR BC-BR-C95-C155
450330	KNOB FOR MAIN SWITCH
461234	PLATE "ELECTRONIC 3"
631214	ANTI-NOISE FILTER 4011135007 3
870027	MAIN SWITCH 200A
870045	SWITCH FOR MAIN SWITCH 200A

Modello	Prelavaggio Prelavage Prewash Vorwaschzone Prelavado 600	Prelavaggio Prelavage Prewash Vorwaschzone Prelavado 900	Lavaggio Lavage Wash Waschzone Lavado 900	2° Lavaggio Lavage Wash Waschzone Lavado 900	Ecorinse Ecorinse Ecorinse Ecorinse Ecorinse	Risciacquo Rincage Rinse Nachspülung Aclarado
NL 302			14 Kw (8kw+6kw)			16 Kw (8kw+8kw)
NL 402			14 Kw (8kw+6kw)			18 Kw (9kw+9kw)
NL 502		9 Kw	14 Kw (8kw+6kw)			21 Kw (6kw+6kw+9kw)
NL 552			12 Kw (6kw+6kw)	14 Kw (8kw+6kw)		23 Kw (8kw+6kw+9kw)
NL 302/E			14 Kw (8kw+6kw)		5 Kw	16 Kw (8kw+8kw)
NL 402/E			14 Kw (8kw+6kw)		5 Kw	18 Kw (9kw+9kw)
NL 502/E		9 Kw	14 Kw (8kw+6kw)		6 Kw	21 Kw (6kw+6kw+9kw)
NL 552/E			12 Kw (6kw+6kw)	14 Kw (8kw+6kw)	6 Kw	23 Kw (8kw+6kw+9kw)

380 - 415V

	5 Kw	110283
	6 Kw	110349
	8 Kw	110343
	9 Kw	110362

18 - Heating Elements

CODE	DESCRIPTION
110283	ECORINSE HEATER 5000W ACRS
110343	HEAT.ELEM. 8000W 220/380V
110349	HEAT.ELEMENT 6000W 230/400V
110362	HEAT.ELEMENT 9000W 220/380V
161102	ELEMENT COVER MOPL.
200815	O-RING F. HEAT.ELEM.

19 - Spring For Counterbalancing doors

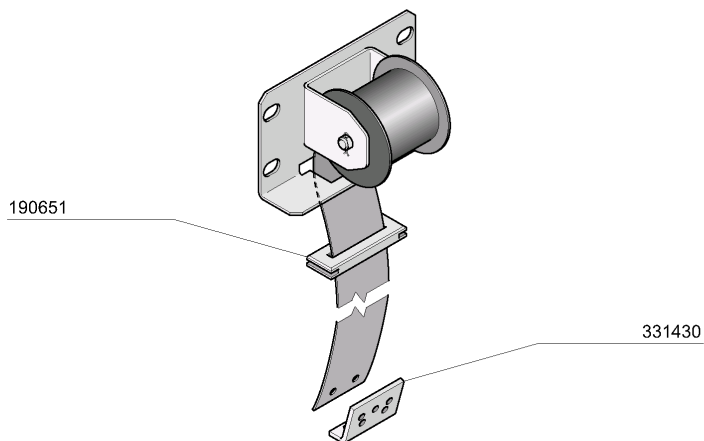

<i>Tipo porta</i> <i>Type porte</i> <i>Door type</i> <i>Türtyp</i> <i>Modelo puerta</i>		3,5 kg	4 kg	5 kg
<i>Cod.</i>		391317	391309	391331
400	Doppia parete Double skin Double paroi Doppelwandig Dobla pared	(2x3,5) kg		
600	Doppia parete Double skin Double paroi Doppelwandig Dobla pared			(2x5) kg
900	Doppia parete Double skin Double paroi Doppelwandig Dobla pared	(4x3,5) kg		
1000	Doppia parete Double skin Double paroi Doppelwandig Dobla pared	(2x3,5) kg	(2x4) kg	

M.G. 01/10

19 - Spring For Counterbalancing doors

CODE	DESCRIPTION
190651	BUSH
331430	BRACKET FOR DOOR SPRING
391309	DOOR SPRING 4KG - 40MM
391317	DOOR SPRING 3,5KG - 40MM
391331	SPRING ASSEMBLY KG. 5 MM 40

1,5 KW 220-240 V | 380-415 V

100752 (50 Hz)
100883 (60 Hz)

2,7 KW 220-240 V | 380-415 V

100782 (50 Hz)
100822 (60 Hz)

"ECORINSE"

0,35 KW 220-240 V | 380-415 V

100647 (50 Hz)
100669 (60 Hz)

220/240 V						380/415 V				
Pompa Pompe Pump Pumpe Bomba		Teleruttore Contacteur Contactor Schalterschütz Contactor		Magnetotermici Magneto-termique Termo-magnetic Magnetischer schalter Magneto-termico		Teleruttore Contacteur Contactor Schalterschütz Contactor		Magnetotermici Magneto-termique Termo-magnetic Magnetischer schalter Magneto-termico		
Hp	Kw	A	cod.	A	cod	A	cod.	A	cod.	
0,46	0,35	9	120428	1 ÷ 1,6	120821	9	120428	0,4 ÷ 0,63	120830	
2	1,5	9	120468	4 ÷ 6	120824	9	120428	2,5 ÷ 4	120823	
3,7	2,7	12	120429	7 ÷ 10	120828	9	120428	4 ÷ 6	120824	

MS. 09/10

CODE	DESCRIPTION
100647	PUMP HP 0,20 220/240/3 4226
100669	PUMP HP 0,12 220/380 60HZ C16
100752	PUMP HP2 ZF800
100782	PUMP LGB ZF 1200 2,7 KW
100822	PUMP SX LGB ZF1200 2,7KW 60HZ
100883	PUMP HP 2 ZF800 60HZ
120428	CONTACTOR 9A 24V 50HZ
120429	CONTACTOR 12A 24V 50HZ
120468	CONTACTOR ABB 9A 24V 50/60HZ
120821	OVERLOAD RELAY 1/1,6A
120823	OVERLOAD RELAY 2.5/4 A
120824	OVERLOAD RELAY 4/6 A
120828	OVERLOAD RELAY 7/10 A
120830	OVERLOAD RELAY 0,40 - 0,63 A
630125	VOLUTE 0,12/0,3(2212-29)
630137	PUMP VOLUTE LGB ZF800DX
630145	PUMP VOLUTE ZF1200
630235	PUMP COVER 0,12/0,3 2212-19
630256	PUMP FLANGE ZF800
630257	PUMP FLANGE ZF1200
630331	COOLING FAN FOR PUMP ZF800
630332	COOLING FAN FOR PUMP ZF1200
630416	OR FOR VOLUTE 0,12/0,3
630426	GASKET LGB ZF800
630432	GASKET FOR PUMP ZF1200
630511	PUMP SEAL HP 0,10 82
630528	SEAL LGB ZF800 2HP
630540	SEAL FOR PUMP ZF1200
631675	ST/ST PUMP IMPELLER 0,2HP 2226
631692	IMPELLER PUMP ZF650/800
631705	IMPELLER 60HZ FOR PUMP 100669
631706	PUMP IMPELLER ZF1200SX
631708	PUMP IMPELLER ZF1200DX
631709	PUMP IMPELLER ZF800 60HZ

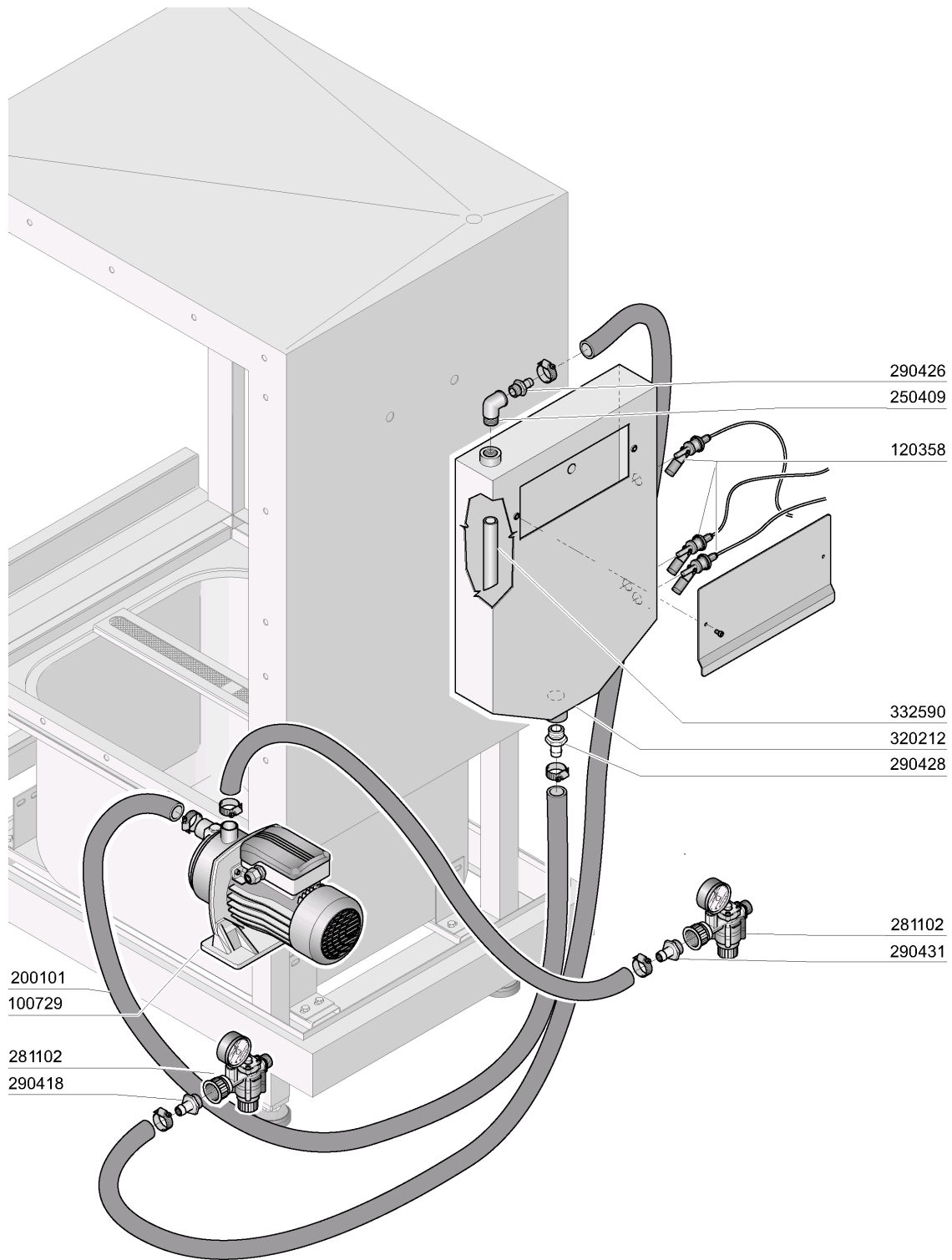

21 - Break tank_TR

CODE	DESCRIPTION
100729	PUMP HP 0,4 220/240V 2HM3T
120358	FLOATING MAGN.SWITCH
200101	RUBBER TUBE 25X35
250409	INOX ELL FF 1/2"
281102	1/2" ADJ VALVE C/W GAUGE TYPE
290418	NIPPLE 1/2"
290426	NIPPLE 1/2"
290428	NIPPLE M.3/4"
290431	NIPPLE 1/2"
320212	BREAK TANK BOX
332590	STAINLESS STEEL HOSE FOR B.T.

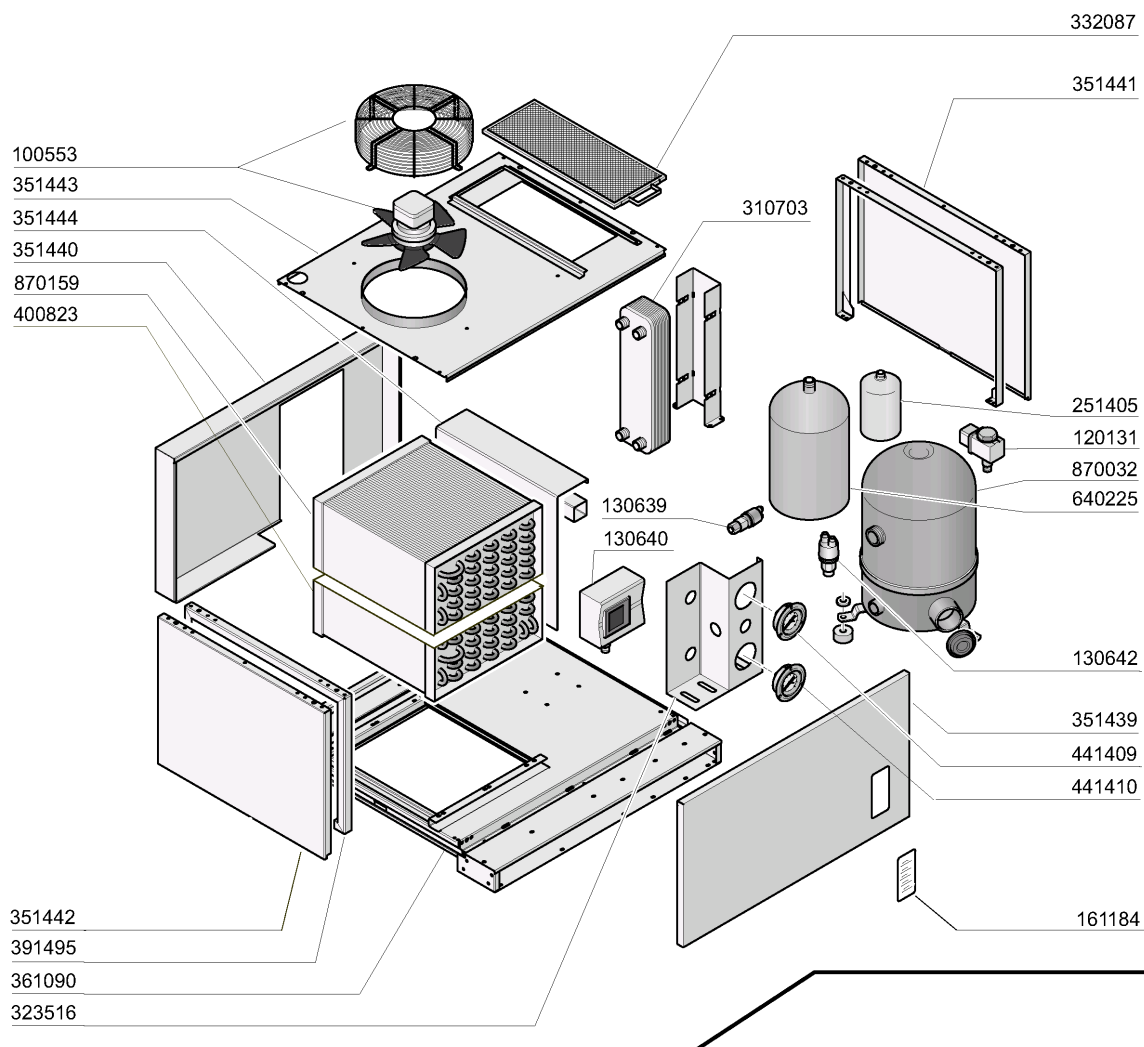

- ① - A x B x C = 298 x 423 x 490 = CODE 870159/RIV
- ① - A x B x C = 230 x 400 x 450 = CODE 870159
- ② - D x E x F = 142 x 490 x 423 = CODE 400823/RIV
- ② - D x E x F = 140 x 450 x 450 = CODE 400823

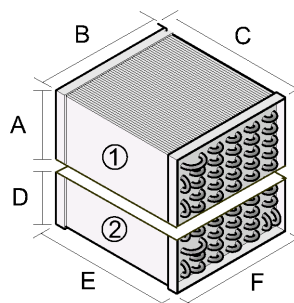

22 - Heat pumps WP4

CODE	DESCRIPTION
100553	WP4 FAN
120131	SOLEN. L182Q31-ZB10A 1/2"24V
130639	LOW PRESSURE SWITCH WP
130640	HIGH PRESSURE SWITCH WP
130642	PRESSURE SWITCH WP4-LOW PRESS.
161184	MANOMETER INSPECTION GLASS
251405	FILTER WP4
310703	RINSE WATER CONDENSOR
323516	MANOMETER SUPPORT
332087	WP4 COVER FILTER
351439	FRONT PANEL 750 MM
351440	BACK PANEL 750MM
351441	ENTRY PANEL 750MM
351442	EXIT PANEL 750MM
351443	UPPER PANEL 750MM
351444	PARZIALIZZATORE WP 750MM
361090	BASEMENT WP4
391495	LEFT SIDE HOOD
400823	BATTERY WP4
400823/RIV	BATTERY WP4
441409	MANOMETRO ASPIRAZIONE (WP)
441410	MANOMETRO CONDENSAZIONE (WP)
640225	LIQUID GAS CONTAINER FOR WP4
870032	COMPRESSOR WP4
870159	EVAPORATOR WP4
870159/RIV	EVAPORATOR WP4

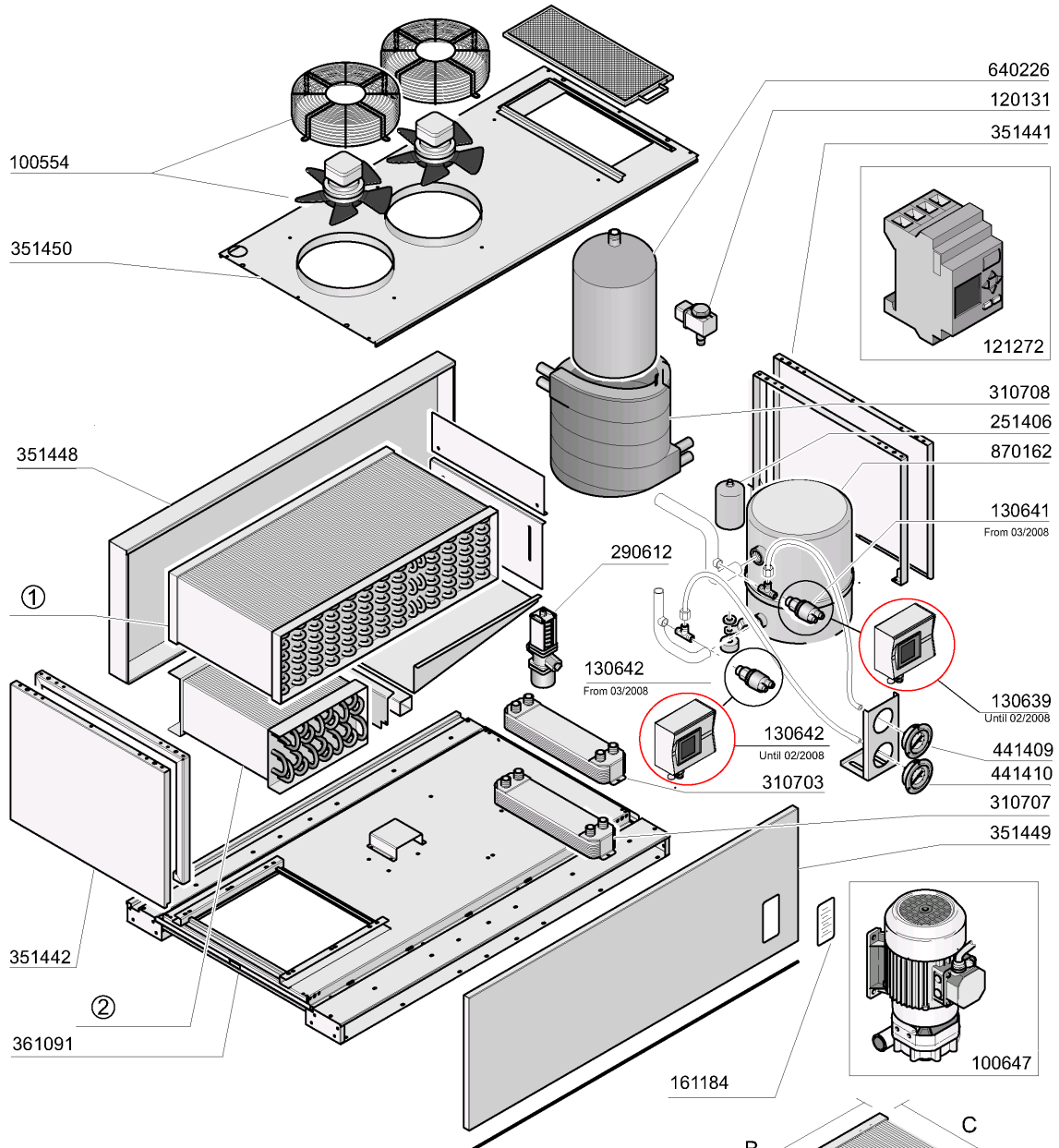

- ① A x B x C = 250 x 800 x 460 = CODE 870164/RIV
- ① A x B x C = 175 x 750 x 450 = CODE 870164
- ② D x E x F = 190 x 460 x 460 = CODE 400824/RIV
- ② D x E x F = 175 x 450 x 450 = CODE 400824

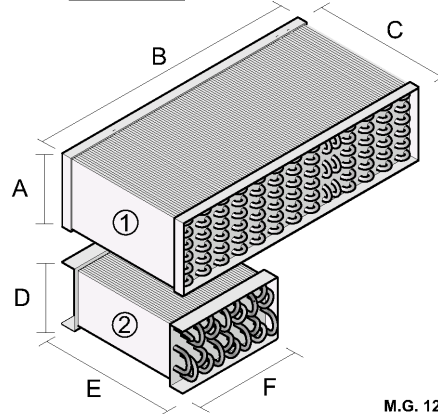



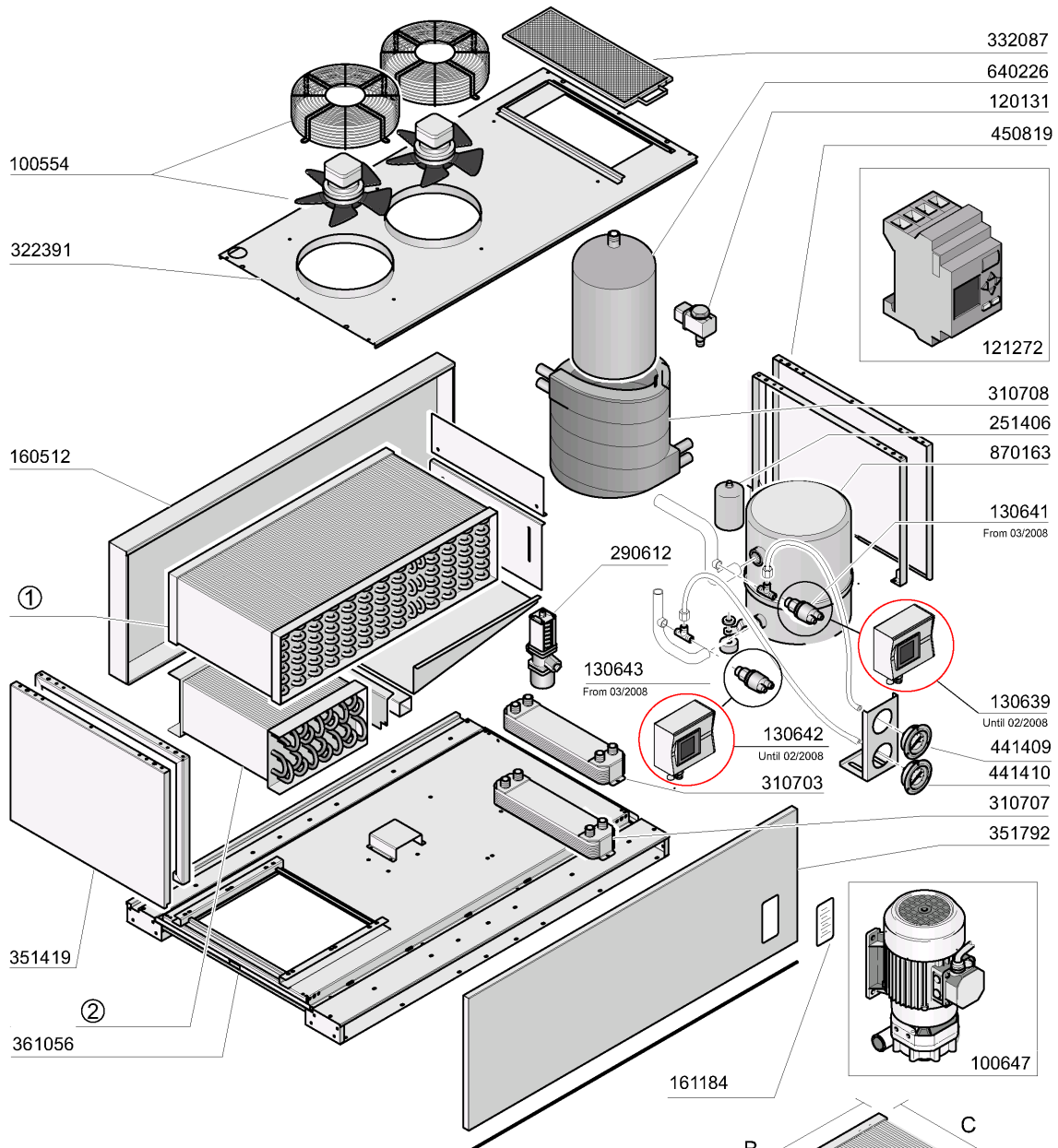

M.G. 12/09

23 - Heat pumps WP6

CODE	DESCRIPTION
100554	WP6/WP8 FAN
100647	PUMP HP 0,20 220/240/3 4226
120131	SOLEN. L182Q31-ZB10A 1/2"24V
121272	PLC
130639	LOW PRESSURE SWITCH WP
130641	PRESSOS WP4 LOW PRESS 2.2 BAR
130642	PRESSURE SWITCH WP4-LOW PRESS.
161184	MANOMETER INSPECTION GLASS
251406	FILTER WP6-WP8
290612	VALVOLA PRESSOSTATICA(WP6-WP8)
310703	RINSE WATER CONDENSOR
310707	CONDENS.GAS/ACQUA BY-PASS (WP)
310708	CONDENSER (WP)
351441	ENTRY PANEL 750MM
351442	EXIT PANEL 750MM
351448	BACK PANEL 1250MM WP
351449	1250MM WP FRONT PANEL
351450	UPPER PANEL 1250MM
361091	BASEMENT WP6
400824	BATTERY WP6
400824/RIV	BATTERY WP6
441409	MANOMETRO ASPIRAZIONE (WP)
441410	MANOMETRO CONDENSAZIONE (WP)
640226	LIQUID GAS CONTAINER FOR WP6-8
870162	COMPRESSOR WP6
870164	EVAPORATOR WP6
870164/RIV	EVAPORATOR WP6



- ①  A x B x C = 250 x 800 x 460 = CODE 870165/RIV
- ①  A x B x C = 175 x 750 x 450 = CODE 870165
- ②  D x E x F = 190 x 460 x 460 = CODE 400825/RIV
- ②  D x E x F = 175 x 450 x 450 = CODE 400825

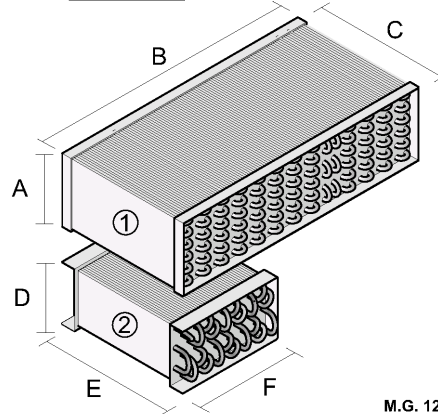

M.G. 12/09

24 - Heat pumps WP8

CODE	DESCRIPTION
100554	WP6/WP8 FAN
100647	PUMP HP 0,20 220/240/3 4226
120131	SOLEN. L182Q31-ZB10A 1/2"24V
121272	PLC
130639	LOW PRESSURE SWITCH WP
130641	PRESSOS WP4 LOW PRESS 2.2 BAR
130642	PRESSURE SWITCH WP4-LOW PRESS.
130643	HIGH PRESSURE PRESS.SWITCH WP
160512	SPACER 35,5
161184	MANOMETER INSPECTION GLASS
251406	FILTER WP6-WP8
290612	VALVOLA PRESSOSTATICA(WP6-WP8)
310703	RINSE WATER CONDENSOR
310707	CONDENS.GAS/ACQUA BY-PASS (WP)
310708	CONDENSER (WP)
322391	PANNELLO SUPERIORE WP 1500MM
332087	WP4 COVER FILTER
351419	FRONT PANEL WP
351792	PANNELLO ANTERIORE WP NE2
361056	BASEMENT WP8
400825	BATTERIA PRERISCALD.ACQUA(WP8)
400825/RIV	BATTERY WP6
441409	MANOMETRO ASPIRAZIONE (WP)
441410	MANOMETRO CONDENSAZIONE (WP)
450819	STAINL.ST SCREW M6
640226	LIQUID GAS CONTAINER FOR WP6-8
870163	COMPRESSORE POMPA WP8
870165	EVAPORATOR WP8
870165/RIV	EVAPORATOR WP8

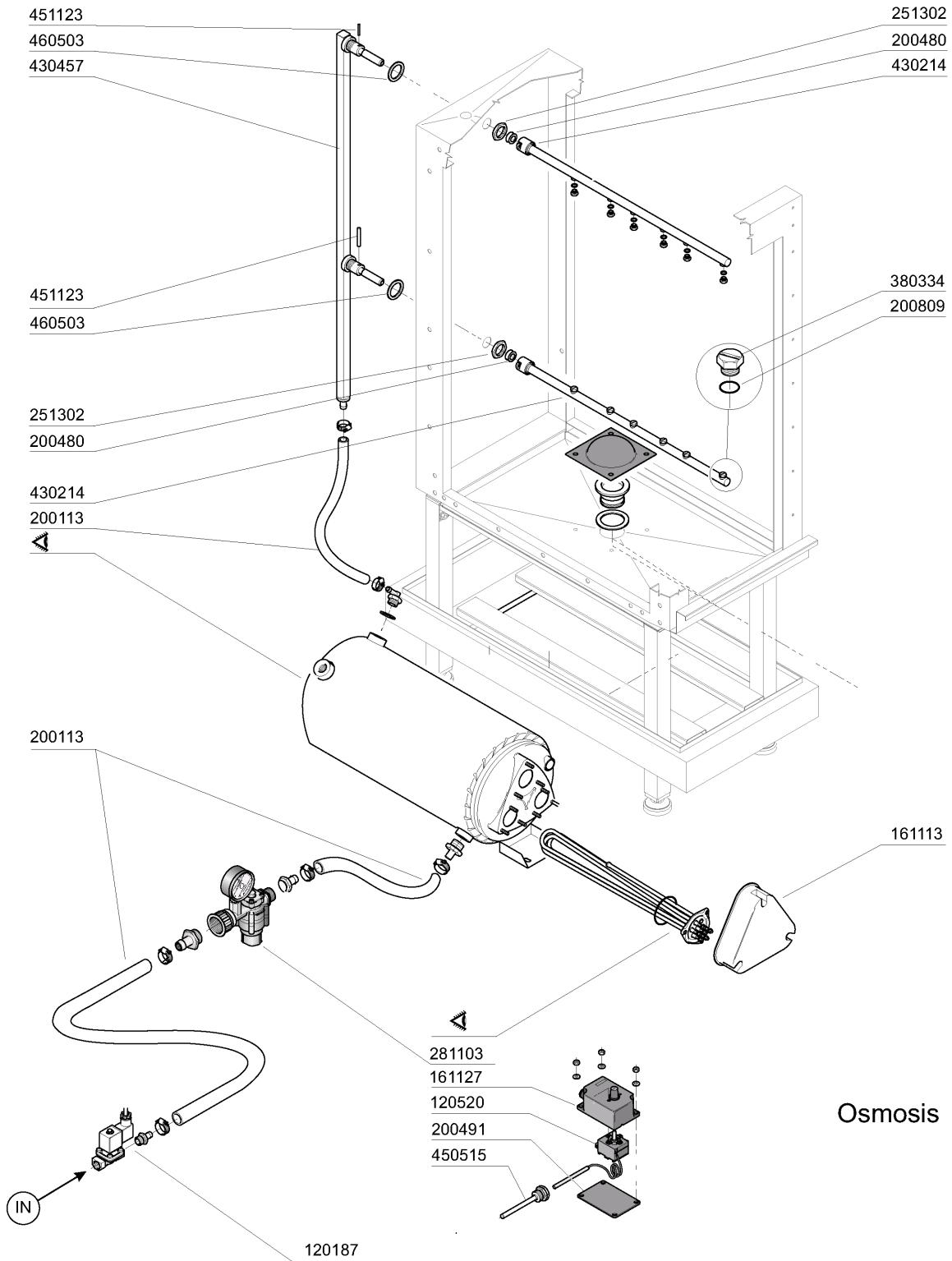

Osmosis

M.G 01/09

CODE	DESCRIPTION
120187	SOLENOID VALVE 3/4" 24V
120520	SECURITY THERMOSTAT 110-130Ø
161113	ELMENT COVER BLACK
161127	BOX FOR THERMOSTAT
200113	RUBBER HOSE 12 X 22
200480	GASKET F. RINSE CONNECT.
200491	BACK GASKET OF THERMOSTAT BOX
200809	OR GASKET 1,78X8,73X12,29
251302	S/S LOCK NUT 3/4" AC-ACR
281103	ADJ. VALUE
380334	JET
430214	RINSE ARM NE02
430457	RINSE COLUMN NE02
450515	STAINL.ST.SHIELD FOR 1 THERMOS
451123	ELASTIC PIN 4X16
460503	SEALING WASHER 38X27X2(3/4)